

Variable speed controllers for asynchronous motors

Characteristics :
pages 60131/7 to 60131/9
Operation :
pages 60131/10 and 60131/11
Dimensions, schemes :
pages 60134/2 to 60135/8
Functions :
pages 60133/2 to 60133/25

Altivar 58

Presentation

Applications

A frequency inverter for 3-phase asynchronous squirrel cage motors, the Altivar 58 incorporates the latest technological developments and functions to meet the requirements of most applications, in particular :

- ventilation/air conditioning
- pumps and compressors
- horizontal and vertical materials handling
- packing/packaging
- specialised machines

Its range of options enable it to be adapted to complex, sophisticated machines.

For applications which only require a little overtorque, speed controllers with power ratings \geq at 208...240 V and \geq 18.5 kW at 380...500 V can be updated.

Functions

Its main functions are :

- starting/stopping, dynamic braking and braking to standstill and speed control
- energy saving, PI regulator (flow rate, pressure, etc)
- brake sequence
- speed control loop with tachogenerator or pulse generator
- +/- speed, S ramps, U ramps, preset speeds, step by step operation (JOG)
- automatic catching a spinning load with speed search (flying restart)
- adapting the current limit to the speed for ventilation applications
- automatic limiting of operating time at low speed, protection of motor and speed controller, etc

Standard versions

The Altivar 58 is available in three standard versions for incorporation in machines.

Standard speed controller with heatsink (item 1)

For normal environments and ventilated enclosures.

Speed controller on base plate (items 2 and 3)

This standard version is designed for applications where the degree of dust and damp-proof protection required by the environment prohibits ventilation.

The speed controller can be mounted in the following ways :

- in a dust and damp-proof enclosure using the heatsink kit sold separately to dissipate the heat to the atmosphere (item 2)
- in the machine chassis if the chassis frame can absorb sufficient heat (item 3)

In both cases there is no requirement for special cut-out, only the speed controller fixing holes.

Ready-assembled speed controller (items 4 and 5)

● Altivar 58 COMPACT power rating \leq 5.5 kW (item 4) :

This ready-to-use IP 55 enclosure is equipped with a speed controller on a base plate with an external heatsink, a circuit-breaker to provide type 2 protection and coordination, and a downstream contactor.

This enclosure can be installed next to the motor.

● Altivar 58 ENERGY power rating \geq 7.5 kW (item 5) :

This IP 55 enclosure is equipped with a speed controller with a cooling system and a Vario isolator switch. There is a slot for an additional contactor. The speed controllers are supplied with an integrated line choke.

This enclosure can be installed next to the motor.

1

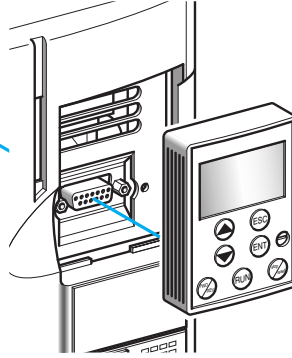

3

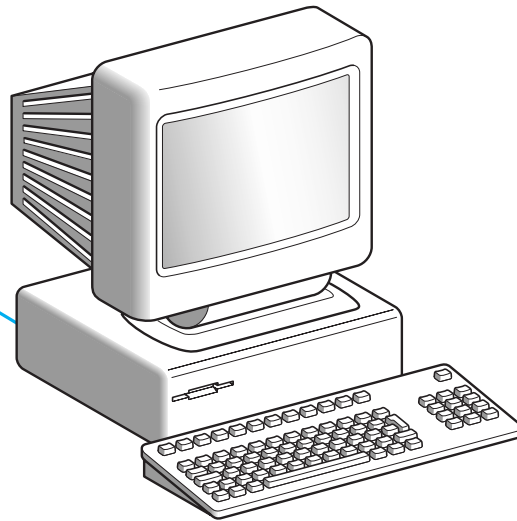

2

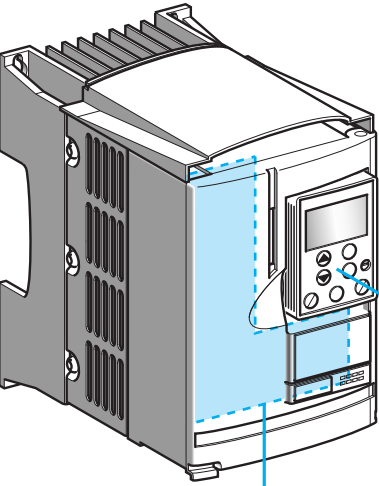

4

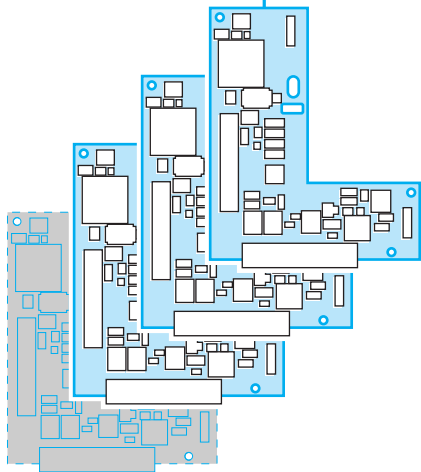

Variable speed controllers for asynchronous motors

Characteristics :
pages 60131/7 to 60131/9
Operation :
pages 60131/10 and 60131/11
Dimensions, schemes :
pages 60134/2 to 60135/8
Functions :
pages 60133/2 to 60133/25

Altivar 58

Presentation (continued)

Fast programming using macro-configurations

The Altivar 58 offers simple, fast programming using macro-configurations which correspond to various applications : materials handling, general use, variable torque.
Each of these configurations is fully adjustable.

Dialogue functions

The Altivar 58 has an RS 485 multidrop serial link with simplified Modbus protocol as part of the standard product. The serial link is used to connect PLCs, a PC or one of the available programming tools.

3 advanced dialogue solutions, with multilingual plain text display and storing of configurations :

- **Operator terminal**, on the speed controller or enclosure door (item **1**) :
 - 5 languages : English, French, German, Spanish, Italian
 - Remote loading of configuration
 - Storage of 4 configuration files
 - Signalling
 - Adjustment, control and configuration
- **Programming terminal** (item **2**) :
 - 2 language groups can be selected : English, Spanish, French or German, English, Italian
 - Remote loading of configuration
 - Storage of 8 configuration files
 - Adjustment, control and configuration
 - Standalone programming without the speed controller
 - Transfer of configuration from PC to speed controller
- **PC interconnection add-on** (item **3**) :
 - 5 languages : English, French, German, Spanish, Italian
 - Remote loading of configuration to speed controller or programming terminal
 - Adjustment, control and configuration
 - Preparation and configuration without speed controller
 - Assisted and standalone programming
 - Storage on diskette or hard disk

Customising the application

It is possible to extend the functions by adding an extension card or communication bus (item **4**).

- **I/O extension cards** :
 - I/O and speed loop with analogue input or encoder input.
- **Communication bus** :
 - Fipio, Uni-Telway/Modbus, Interbus-S, Modbus Plus, AS-i or Profibus DP communication bus.
- **Customer specific card on request** :
 - Software functions, example special cycle and servo control
 - Hardware functions, example special inputs or outputs

Cards are already available for :

 - switching pumps
 - multi-motor operation
 - multi-parameter entry

Electromagnetic compatibility

- **Integrated EMC filters** :

ATV-58 speed controllers are available with integrated EMC filters. Incorporating filters into the speed controllers facilitates machine installation and conformity for CE marking purposes at low cost.
They are sized to conform to the following standards : EN 61800-3/IEC 1800-3 for residential and industrial environments.
ATV-58 speed controllers with power ratings ≥ 18.5 kW at 380...500 V are also available without EMC filters, where EMC conformity is not required.
Speed controllers with power ratings ≥ 11 kW at 208...240 V are not available with integrated EMC filters.
- **Line chokes** :

ATV-58 with power ratings ≥ 11 kW at 208...240 V and ≥ 18.5 kW at 380...500 V, are available with integrated line chokes which limit the line current to the motor nominal current value.
Separate line chokes are available as an option for the other power ratings.

Variable speed controllers for asynchronous motors

Characteristics :
pages 60131/7 to 60131/9
Operation :
pages 60131/10 and 60131/11
Dimensions, schemes :
pages 60134/2 to 60135/8
Functions :
pages 60133/2 to 60133/25

Altivar 58

Presentation (continued)

Operator terminal

The Altivar 58 is fitted with a housing on the front panel for a plug-in operator terminal which can be supplied with the speed controller or ordered separately. It can be used for :

- controlling, adjusting and configuring the speed controller
- visible remote signalling
- storing and downloading configurations

A "remote terminal" option enables it to be remotely mounted on the door of an enclosure with an IP 65 protected front panel, using a 3m cable.

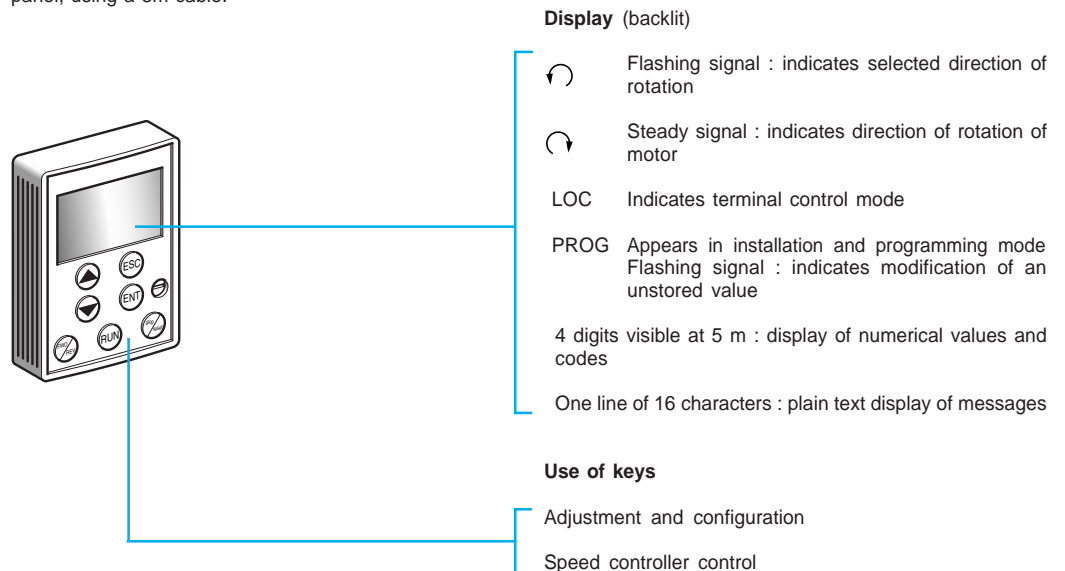

Programming terminal

The programming terminal can be used for the preparation, programming, installation and maintenance of the drive. It can be used :

- for preparing and storing configuration/adjustment files (power supply via internal battery)
- connected to a PC to record and store configuration/adjustment files prepared on the PC using the PC interconnection add-on
- connected to the speed controller to adjust and configure it or to load a previously prepared file.

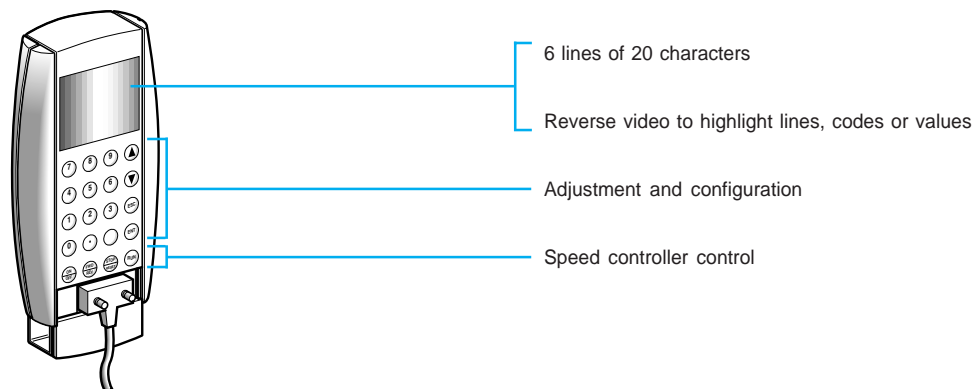

PC interconnection option

The PC interconnection option is used to link the Altivar or programming terminal with a PC microcomputer in a Microsoft Windows version 3.1. or Windows 95 environment.

The connection is via a serial link using the terminal port and the microcomputer serial port.

The software performs all the programming terminal functions (speed controller configuration and adjustment, control, signalling, etc) and in addition offers :

- copying and saving of configurations to diskette or hard disk
- copying and saving of configurations in the programming terminal using the PC, and vice versa
- paper print-out of the speed controller configuration
- assisted and guided operator dialogue in 5 languages in a Windows environment

Variable speed controllers for asynchronous motors

Presentation :
pages 60131/2 to 60131/6
Function :
pages 60131/10 and 60131/11
Dimensions, schemes :
pages 60134/2 to 60135/8
Functions :
pages 60133/2 to 60133/25

Altivar 58

Characteristics

Environment

Conformity to standards		Altivar 58 speed controllers have been developed to conform to National and International standards and the recommendations for electrical industrial control devices (IEC, EN, NFC, VDE), notably : <ul style="list-style-type: none"> ● Low Voltage EN 50178, ● EMC immunity : <ul style="list-style-type: none"> - IEC 1000-4-2/EN 61000-4-2 level 3 - IEC 1000-4-3/EN 61000-4-3 level 3 - IEC 1000-4-4/EN 61000-4-4 level 4 - IEC 1000-4-5/EN 61000-4-5 level 3 - IEC 1800-3/EN 61800-3, environments 1 and 2 ● EMC, conducted and radiated emissions : <ul style="list-style-type: none"> - IEC 1800-3/EN 61800-3, environments 1 (public sector) and 2 (industrial sector) under restricted distribution - EN 55011 class A (speed controllers with radio interference filters included) - EN 55022 class B, with additional filters
CE marking		The speed controllers have been developed according to the European low voltage (73/23/CEE and 93/68/CEE) and EMC (89/336/CEE) directives. For this reason, Altivar 58 speed controllers are marked with the CE European Community mark.
Product certification		UL and CSA
Degree of protection		Unprotected speed controllers : IP 21, and IP 41 on upper part (conforming to EN 50178)
Vibration resistance		Conforming to IEC 68-2-6 : <ul style="list-style-type: none"> ● 1.5 mm peak from 2 to 13 Hz ● 1 g from 13 to 200 Hz
Shock resistance		Conforming to IEC 68-2-27 : 15 g for 11 ms
Maximum ambient pollution		ATV-58HD16M2X to HD46M2X, ●D28N4 to ●D79N4 and HD28N4X to HD79N4X speed controllers : degree 3 conforming to UL 508C Other speed controllers : degree 2 conforming to IEC 664-1 and EN 50718
Maximum relative humidity		93 % with no condensation or dripping water, conforming to IEC 68-2-3
Ambient air temperature around the device	Storage Operation	°C °C
		- 25...+ 65 ATV-58P●●●● speed controllers, all ratings : - 10...+ 40 ATV-58HU09M2 to HU72M2 and HU18N4 to HU90N4 speed controllers : <ul style="list-style-type: none"> ● - 10...+ 50 with no derating ● Up to + 60 derating the current by 2.2 % per °C over 50 °C ATV-58HU90M2 to HD12M2 and HD12N4 to HD23N4 speed controllers : <ul style="list-style-type: none"> ● - 10...+ 40 with no derating ● Up to + 50 derating the current by 2.2 % per °C over 40 °C ATV-58HD16M2X to HD46M2X, HD28N4 to HD79N4 and HD28N4X to HD79N4X speed controllers : <ul style="list-style-type: none"> ● - 10...+ 40 with no derating ● Up to + 60 with fan kit derating the current by 2.2 % per °C over 40 °C
Maximum operating altitude	m	1000 with no derating (above this derate the current by 1 % per additional 100 m)
Operating position		Vertical

Drive characteristics

Output frequency range	Hz	0.1...500
Configurable switching frequency	kHz	<ul style="list-style-type: none"> ● No derating, in continuous operation : 0.5-1-2-4 for ATV-58●U09M2 to ●D12M2, HD16M2X and HD23M2X, ●U18N4 to ●D46N4 and HD28N4X to HD46N4X speed controllers 0.5-1-2 for ATV-58HD28M2X to HD46M2X, ●D54N4 to ●D79N4 and HD54N4X to HD79N4X speed controllers ● No derating with intermittent operating cycle or with derating by one power rating in continuous operation: 8-12-16 for ATV-58●U09M2 to ●D12M2 and ●U18N4 to ●D23N4 speed controllers 8-12 for ATV-58HD16M2X, HD23M2X, ●D28N4 to ●D46N4 and HD28N4X to HD46N4X speed controllers 4-8 for ATV-58HD28M2X to HD46M2X, ●D54N4 to ●D79N4 and HD54N4X to HD79N4X speed controllers
Speed range		1...100
Speed precision For a torque variation from 0.2 Cn to Cn		<ul style="list-style-type: none"> ● ± 1 % of the nominal speed, without speed feedback ● ± 0.1 % of the nominal speed, with tachogenerator speed feedback (option card) ● ± 0.02 % of the nominal speed, with encoder feedback (option card)
Transient overtorque		200 % (140 % in standard torque) of the nominal motor torque (typical value at ± 10 %) for 2 s 170 % (120 % in standard torque) of the nominal motor torque (typical value at ± 10 %) for 60 s
Braking torque		30% of the nominal motor torque with no braking resistor (typical value). Up to 150% with braking resistor as option
Voltage/frequency ratio		Sensorless flux vector control : constant torque, variable torque or energy saving, configurable

Variable speed controllers for asynchronous motors

Presentation :
pages 60131/2 to 60131/6
Operation :
pages 60131/10 and 60131/11
Dimensions, schemes :
pages 60134/2 to 60135/8
Functions :
pages 60133/2 to 60133/25

Altivar 58

Characteristics (continued)

Electrical characteristics

Power supply Voltage	V	ATV-58●●●●M2 speed controllers : 200 - 10 % to 240 + 10 % single phase and 3-phase ATV-58HD●●M2X speed controllers : 208 - 10 % to 240 + 10 % 3-phase ATV-58●●●●N4 and ●●●●N4X speed controllers : 380 - 10 % to 500 + 10 % 3-phase
Frequency	Hz	50 ± 5 % or 60 ± 5 %
Output voltage		Maximum voltage equal to mains voltage
Electrical isolation		Electrical isolation between power and control (inputs, outputs, supplies)
Available internal supplies		Protected against short-circuits and overloads 1 + 10 V ± 1 % supply for the reference potentiometer (1...10 kΩ), maximum current 10 mA 1 + 24 V supply (min 20 V, max 30 V) for control inputs, maximum current 200 mA
Analogue inputs AI		1 analogue voltage input AI1 : range 0-10 V, impedance 30 kΩ 1 analogue current input AI2 : range 0-20 mA, impedance 100 Ω (reassignable to X-Y mA by programming X and Y, with a definition of 0.1 mA) Frequency resolution in analogue reference : 0.1 Hz for 100 Hz (10 bits) Accuracy ± 1%, linearity ± 0.5% of the maximum output frequency Sampling time : 4 ms maximum Other inputs : see option cards
Logic inputs LI		4 assignable logic inputs with impedance 3.5 kΩ, compatible with PLC level 1, standard IEC 65A-68 Maximum length of shielded cable : 100 m Power supply + 24 V (min. 11 V, max. 30 V). State 0 if < 5 V, state 1 if ≥ 11 V Sampling time : 2 ms maximum Other inputs : see option cards
Logic outputs		2 relay logic outputs for R1 (fault relay) and R2 (assignable) 1 C/O contact protected against overvoltages (relay R1) 1 N/O contact protected against overvoltages (relay R2) Minimum switching capacity : 10 mA for ~ 24 V Maximum switching capacity : ● on a resistive load (cos φ = 1) : 5 A for ~ 250 V or ~ 30 V ● on an inductive load (cos φ = 0.4 and L/R = 7 ms) : 1.5 A for ~ 250 V or ~ 30 V Other outputs : see option cards
Communication		RS 485 multidrop serial link with simplified Modbus protocol as part of the standard product. Transmission speed : 19 200 bps, no parity Use : - connecting a terminal (option) or - connecting a microprocessor card or - connecting a PC (option) or - connecting one or more PLCs
Acceleration and deceleration ramps		Shape of ramps can be selected : linear or S or U Preset in factory to 3 s Possibility of 2 ranges of ramps which can be switched by frequency threshold or logic input Can be adjusted separately from 0.05-0.1 to 999.9 s (definition to 0.1 s) Automatic adaptation of the deceleration ramp times if the braking capacity is exceeded (configurable choice)
Braking to standstill		By d.c. injection : ● by a signal on an assignable logic input ● automatically on stopping as soon as the frequency drops below 0.1 Hz, for a time adjustable from 0 to 30 s or alternately set - continuous
Main protection and safety features of the speed controller		Short-circuit protection : ● between output phases ● between output phases and earth ● on the outputs of internal supplies Thermal protection against excessive overheating and overcurrents Mains undervoltage and overvoltage Mains supply phase loss of phase (prevents single phase operation of 3-phase speed controllers)
Motor protection		Thermal protection integrated in the speed controller by continuous calculation of I ² t taking the speed into account ● Saving of motor thermal state when speed controller is powered down ● Function can be modified using the terminal depending on type of motor cooling, force-cooled or self-cooled Protection against motor loss of phase Protection via PTC probes with option card
Insulation resistance to earth	MΩ	> 500 (electrical insulation)

Variable speed controllers for asynchronous motors

Presentation :
pages 60131/2 to 60131/6
Operation :
pages 60131/10 and 60131/11
Dimensions, schemes :
pages 60134/2 to 60135/8
Functions :
pages 60133/2 to 60133/25

Altivar 58

Characteristics (continued)

Torque characteristics (typical curves)

The curves below define the available continuous torque and transient overtorque, either on a self-cooled or a force-cooled motor. The only difference is in the ability of the motor to provide a high continuous torque at less than half nominal speed.

High torque applications

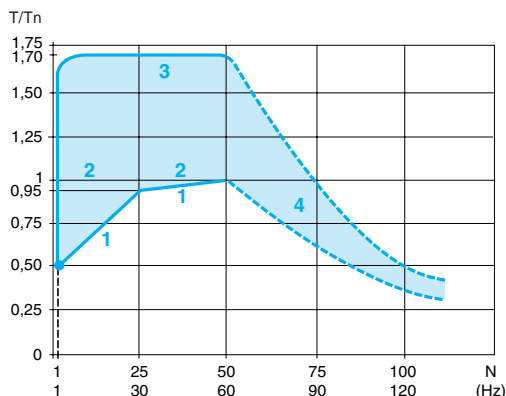

- 1 Self-cooled motor : continuous useful torque (1)
- 2 Force-cooled motor : continuous useful torque
- 3 Transient overtorque
- 4 Torque in overspeed at constant power (2)

Standard torque applications

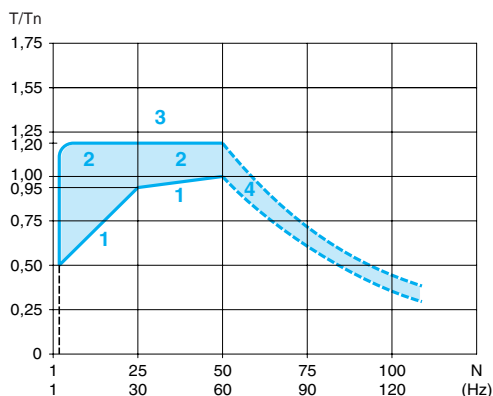

- 1 Self-cooled motor : continuous useful torque (1)
- 2 Force-cooled motor : continuous useful torque
- 3 Transient overtorque
- 4 Torque in overspeed at constant power (2)

Motor thermal protection

The Altivar 58 speed controller offers motor thermal protection which has been specially designed for the operation at variable speed of self-cooled or force-cooled motors.

This motor thermal protection is intended for a maximum ambient temperature of 40 °C around the motor.

If the temperature around the motor exceeds 40 °C, direct external thermal protection must be provided via thermistor probes integrated in the motor, using one of the option cards.

(1) For power ratings ≤ 250 W, derating is 20 % instead of 50 % at very low frequency.

(2) The nominal frequency of the motor and the maximum output frequency can be adjusted from 40 to 500 Hz.

Warning : Ask the manufacturer for the mechanical overspeed capability of the selected motor.

Variable speed controllers for asynchronous motors

Presentation :
pages 60131/2 to 60131/6
Characteristics :
pages 60131/7 to 60131/9
Dimensions, schemes :
pages 60134/2 to 60135/8
Functions :
pages 60133/2 to 60133/25

Altivar 58

Operation

Special uses

Power of the motor lower than the power of the speed controller

The Altivar 58 speed controller can supply any motor with a power level lower than that for which it is designed. This solves the problem of applications requiring high levels of intermittent overtorque.

Examples : machines with very high starting torque, crushers, kneaders, etc.

Note : In this case, we recommend oversizing the speed controller to one size above that of the motor. Example : connecting an 11 kW motor to a 15 kW speed controller.

Power of the motor higher than the power of the speed controller

A motor with a power level higher than that of the speed controller can be used as long as the current drawn by the motor is lower than or equal to the nominal current of the speed controller. This gives a self-cooled motor a greater speed range in continuous operation.

Note : Limit the power of the motor to one size above that of the speed controller.

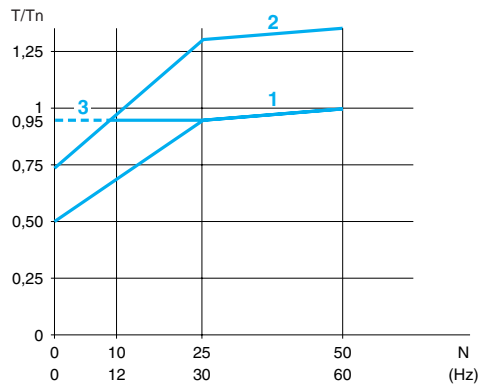

Example : connecting a 2.2 kW speed controller to a 3 kW motor (the 3 kW motor is to be used as a 2.2 kW motor with a speed range of 10 to 50 Hz).

- 1 Continuous motor torque
Example : 2.2 kW
Motor power = speed controller power
- 2 Continuous motor torque
Example : 3 kW
Motor power > speed controller power
- 3 2.2 kW speed controller : nominal current

Connecting motors in parallel

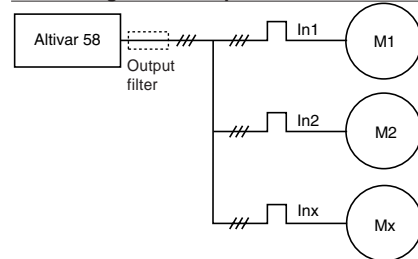

The nominal current of the speed controller must be higher than or equal to the sum of the currents of the motors which are to be controlled.

In this case, external thermal protection must be provided for each motor via probes or thermal overload relays. If the number of motors connected in parallel is ≥ 3 , it is recommended that an output filter is installed between the speed controller and the motors, or that the switching frequency is reduced.

Determining the speed controller rating :
Speed controller $I_n > I_{n1} + I_{n2} + \dots + I_{nx}$.

When using several motors in parallel, there are two possibilities :

- the motors have equivalent power ratings : in this case the torque performance levels remain optimised after the speed controller has been adjusted,
- the motors have different power ratings : in this case the speed controller adjustment is incompatible with motors with lower power ratings and the low speed overtorque is considerably reduced.

Using a motor at overspeed

The maximum output frequency of the speed controller can be adjusted from 40 to 500 Hz. Before using a standard asynchronous motor at overspeed, ask the manufacturer for the mechanical overspeed capabilities of the selected motor.

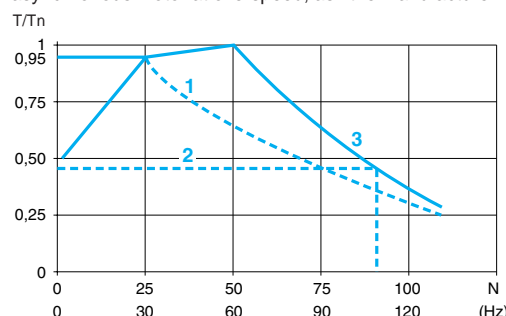

Above its nominal speed corresponding to a frequency of 50/60 Hz, the motor runs with decreasing flux and its torque decreases considerably (see curve opposite).

The application must function at reduced torque operation at very high speed.

- 1 Machine torque (decreasing torque)
- 2 Machine torque (low driving torque)
- 3 Continuous motor torque

Typical applications : woodworking machines, increasing the operational speed range of lightly loaded motors.

Variable speed controllers for asynchronous motors

Presentation :
pages 60131/2 to 60131/6
Characteristics :
pages 60131/7 to 60131/9
Dimensions, schemes :
pages 60134/2 to 60135/8
Functions :
pages 60133/2 to 60133/25

Altivar 58

Operation (continued)

Special uses (continued)

Using a motor at constant torque up to 87/104 Hz

A 400 V, 50 Hz motor with a Δ connection can be used at constant torque up to 87 Hz with a Δ connection. In this special case, the initial power of the motor and the power of the first connected speed controller are multiplied by $\sqrt{3}$ (a speed controller of suitable power must therefore be selected).

Example : a 2.2 kW, 50 Hz motor with a Δ connection supplies a power of 3.8 kW at 87 Hz with a Δ connection. (establish the overspeed capabilities of the motor).

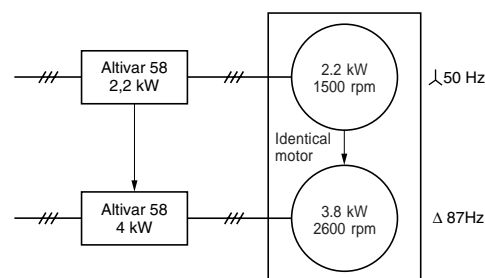
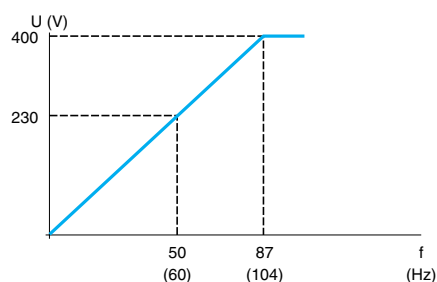

Using special motors

- Special motor-brake units : tapered rotor or flux bypass.
The motor magnetic field releases the brake. This operation with the Altivar 58 speed controller requires adjustment of the low frequency voltage.
Note : The no-load current can be high but operation at low speed may only be intermittent.
- Synchronised synchronous or asynchronous motors.
These motors have a low level of self-inductance and require chokes fitted in series. The low speed torque remains limited. Special adjustments are required (suppression of slip compensation, adjustment of motor power supply ratio).
- Asynchronous motors with resistant rotor.
The high slip level of these motors limits the low speed torque. Special adjustments are required (adjustment of slip compensation and motor power supply ratio).
- Special high speed motors.
These motors are designed for constant torque applications with high frequency ranges : 0 to 200/500 Hz. In certain cases an output filter is required between the speed controller and the motor.

Switching the motor on the speed controller output

Switching is possible with the speed controller locked or unlocked. When switching on-the-fly (speed controller unlocked), the motor is controlled and accelerates smoothly up to the reference speed in accordance with the acceleration ramp. This application requires that "flying restart" is configured and "motor phase failure" protection is disabled.

Example : breaking of the downstream contactor.

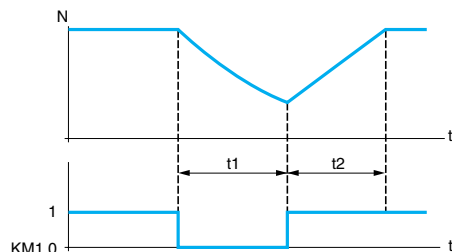

t1 : deceleration without ramp (freewheel)
t2 : acceleration with ramp

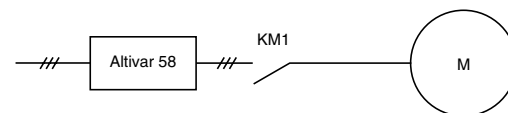

Typical applications : safety break on speed controller output, bypass function, switching of motors connected in parallel.

Operation with intermittent cycle and high switching frequency

It is possible to operate with a high switching frequency (1) with no derating of power if the operating conditions are intermittent and within the following limits :
Cumulative running time 36 s max per 60 s cycle (load factor 60 %).

(1) Possible frequencies (in kHz) :
- 8-12-16 for ATV-58●U09M2 to ●D12M2 and ●U18N4 to ●D23N4 speed controllers,
- 8-12 for ATV-58HD16M2X, HD23M2X and HD28N4 to HD46N4 speed controllers,
- 4-8 for ATV-58HD28M2X to HD46M2X and HD54N4 to HD79N4 speed controllers.

Variable speed controllers for asynchronous motors

Altivar 58
with heatsink

Possible combinations

Compatibility with integrated EMC filters (see page 60132/2)

Supply Supply voltage 50/60 Hz	Motor Power indicated on rating plate		ATV-58 speed controllers for applications with standard with high torque (120 % Tn)		Options	1 communication choke	Remote or extension card	Programming operator terminal	PC terminal (1)	interconnection
	kW	HP			Line torque (170 % Tn)	See p. 60139/3 See p. 60140/3	See p. 60138/2	See p. 60138/2	See p. 60138/3	
200...240 V single phase	0.37	0.5	–	ATV-58HU09M2	VZ1-L004M010	VW3-A58●●●	VW3-A58103	VW3-A58102L●	VW3-A58104	
	0.75	1	–	ATV-58HU18M2	VZ1-L007UM50	VW3-A58●●●	VW3-A58103	VW3-A58102L●	VW3-A58104	
	1.5	2	–	ATV-58HU29M2	VZ1-L018UM20	VW3-A58●●●	VW3-A58103	VW3-A58102L●	VW3-A58104	
	2.2	3	–	ATV-58HU41M2	VZ1-L018UM20	VW3-A58●●●	VW3-A58103	VW3-A58102L●	VW3-A58104	
	3	–	–	ATV-58HU72M2	VW3-A58501	VW3-A58●●●	VW3-A58103	VW3-A58102L●	VW3-A58104	
	4	5	–	ATV-58HU90M2	VW3-A58502	VW3-A58●●●	VW3-A58103	VW3-A58102L●	VW3-A58104	
	5.5	7.5	–	ATV-58HD12M2	VW3-A58502	VW3-A58●●●	VW3-A58103	VW3-A58102L●	VW3-A58104	
200...240 V 3-phase	1.5	2	–	ATV-58HU29M2	VW3-A66502	VW3-A58●●●	VW3-A58103	VW3-A58102L●	VW3-A58104	
	2.2	3	–	ATV-58HU41M2	VW3-A66503	VW3-A58●●●	VW3-A58103	VW3-A58102L●	VW3-A58104	
	3	–	–	ATV-58HU54M2	VW3-A66503	VW3-A58●●●	VW3-A58103	VW3-A58102L●	VW3-A58104	
	4	5	–	ATV-58HU72M2	VW3-A66504	VW3-A58●●●	VW3-A58103	VW3-A58102L●	VW3-A58104	
	5.5	7.5	–	ATV-58HU90M2	VW3-A66504	VW3-A58●●●	VW3-A58103	VW3-A58102L●	VW3-A58104	
	7.5	10	–	ATV-58HD12M2	VW3-A66504	VW3-A58●●●	VW3-A58103	VW3-A58102L●	VW3-A58104	
380...500 V 3-phase	0.75	1	–	ATV-58HU18N4	VW3-A66501	VW3-A58●●●	VW3-A58103	VW3-A58102L●	VW3-A58104	
	1.5	2	–	ATV-58HU29N4	VW3-A66501	VW3-A58●●●	VW3-A58103	VW3-A58102L●	VW3-A58104	
	2.2	3	–	ATV-58HU41N4	VW3-A66502	VW3-A58●●●	VW3-A58103	VW3-A58102L●	VW3-A58104	
	3	–	–	ATV-58HU54N4	VW3-A66502	VW3-A58●●●	VW3-A58103	VW3-A58102L●	VW3-A58104	
	4	5	–	ATV-58HU72N4	VW3-A66502	VW3-A58●●●	VW3-A58103	VW3-A58102L●	VW3-A58104	
	5.5	7.5	–	ATV-58HU90N4	VW3-A66503	VW3-A58●●●	VW3-A58103	VW3-A58102L●	VW3-A58104	
	7.5	10	–	ATV-58HD12N4	VW3-A66503	VW3-A58●●●	VW3-A58103	VW3-A58102L●	VW3-A58104	
	11	15	–	ATV-58HD16N4	VW3-A66504	VW3-A58●●●	VW3-A58103	VW3-A58102L●	VW3-A58104	
	15	20	–	ATV-58HD23N4	VW3-A66504	VW3-A58●●●	VW3-A58103	VW3-A58102L●	VW3-A58104	
	18.5	25	–	ATV-58HD28N4	Integrated	VW3-A58●●●	VW3-A58103	VW3-A58102L●	VW3-A58104	
	22	30	–	ATV-58HD33N4	Integrated	VW3-A58●●●	VW3-A58103	VW3-A58102L●	VW3-A58104	
			–	ATV-58HD28N4	–	Integrated	VW3-A58●●●	VW3-A58103	VW3-A58102L●	VW3-A58104
	30	40	–	ATV-58HD46N4	Integrated	VW3-A58●●●	VW3-A58103	VW3-A58102L●	VW3-A58104	
			–	ATV-58HD33N4	–	Integrated	VW3-A58●●●	VW3-A58103	VW3-A58102L●	VW3-A58104
	37	50	–	ATV-58HD54N4	Integrated	VW3-A58●●●	VW3-A58103	VW3-A58102L●	VW3-A58104	
		–	ATV-58HD46N4	–	Integrated	VW3-A58●●●	VW3-A58103	VW3-A58102L●	VW3-A58104	
45	60	–	ATV-58HD64N4	Integrated	VW3-A58●●●	VW3-A58103	VW3-A58102L●	VW3-A58104		
		–	ATV-58HD54N4	–	Integrated	VW3-A58●●●	VW3-A58103	VW3-A58102L●	VW3-A58104	
55	75	–	ATV-58HD79N4	Integrated	VW3-A58●●●	VW3-A58103	VW3-A58102L●	VW3-A58104		
		–	ATV-58HD64N4	–	Integrated	VW3-A58●●●	VW3-A58103	VW3-A58102L●	VW3-A58104	
75	100	–	ATV-58HD79N4	–	Integrated	VW3-A58●●●	VW3-A58103	VW3-A58102L●	VW3-A58104	

(1) Reference to be completed according to the language required : 1 for English, Spanish and French ; 2 for German, English and Italian.

RS 485 interconnection	Additional input filter	Output filter	Braking module	IP 00 braking resistor	IP 30 braking resistor	Kit for mounting IP 23 air exchanger	Control card fan kit	Plug-in power terminal block
See p. 60138/3	See p. 60143/3	See p. 60144/3	See p. 60141/4	See p. 60141/4	See p. 60141/5	See p. 60132/5	See p. 60132/6	See p. 60132/7
VW3-A58306	VW3-A58401	–	VW3-A58701	VW3-A58702	VW3-A58732	–	VW3-A58821	VW3-A58811
VW3-A58306	VW3-A58401	VW3-A58451	VW3-A58701	VW3-A58702	VW3-A58732	–	VW3-A58821	VW3-A58811
VW3-A58306	VW3-A58402	VW3-A58451	Integrated	VW3-A58702	VW3-A58732	–	VW3-A58822	VW3-A58812
VW3-A58306	VW3-A58402	VW3-A58452	Integrated	VW3-A58704	VW3-A58733	–	VW3-A58822	VW3-A58812
VW3-A58306	VW3-A58403	VW3-A58452	Integrated	–	VW3-A58736	–	VW3-A58823	VW3-A58813
VW3-A58306	VW3-A58404	VW3-A58452	Integrated	–	VW3-A58737	–	VW3-A58824	–
VW3-A58306	VW3-A58404	VW3-A58453	Integrated	–	VW3-A58737	–	VW3-A58824	–
VW3-A58306	VW3-A58402	VW3-A58451	Integrated	VW3-A58702	VW3-A58732	–	VW3-A58822	VW3-A58812
VW3-A58306	VW3-A58402	VW3-A58452	Integrated	VW3-A58704	VW3-A58733	–	VW3-A58822	VW3-A58812
VW3-A58306	VW3-A58403	VW3-A58452	Integrated	VW3-A58704	VW3-A58733	–	VW3-A58823	VW3-A58813
VW3-A58306	VW3-A58403	VW3-A58452	Integrated	–	VW3-A58736	–	VW3-A58823	VW3-A58813
VW3-A58306	VW3-A58404	VW3-A58452	Integrated	–	VW3-A58737	–	VW3-A58824	–
VW3-A58306	VW3-A58404	VW3-A58453	Integrated	–	VW3-A58737	–	VW3-A58824	–
VW3-A58306	VW3-A58402	VW3-A58451	Integrated	VW3-A58702	VW3-A58732	–	VW3-A58822	VW3-A58812
VW3-A58306	VW3-A58402	VW3-A58451	Integrated	VW3-A58702	VW3-A58732	–	VW3-A58822	VW3-A58812
VW3-A58306	VW3-A58402	VW3-A58451	Integrated	VW3-A58702	VW3-A58732	–	VW3-A58822	VW3-A58812
VW3-A58306	VW3-A58403	VW3-A58451	Integrated	VW3-A58703	VW3-A58734	–	VW3-A58823	VW3-A58813
VW3-A58306	VW3-A58403	VW3-A58451	Integrated	VW3-A58703	VW3-A58734	–	VW3-A58823	VW3-A58813
VW3-A58306	VW3-A58403	VW3-A58452	Integrated	–	VW3-A58735	–	VW3-A58823	VW3-A58813
VW3-A58306	VW3-A58404	VW3-A58452	Integrated	–	VW3-A58735	–	VW3-A58824	–
VW3-A58306	VW3-A58404	VW3-A58452	Integrated	–	VW3-A58736	–	VW3-A58824	–
VW3-A58306	VW3-A58405	VW3-A58453	Integrated	–	VW3-A58736	–	VW3-A58824	–
VW3-A58306	VW3-A58406	VW3-A66412	Integrated	–	VW3-A58737	VW3-A58806	VW3-A58825	–
VW3-A58306	VW3-A58407	VW3-A66412	Integrated	–	VW3-A58737	VW3-A58806	VW3-A58825	–
VW3-A58306	VW3-A58406	VW3-A66412	Integrated	–	VW3-A58737	VW3-A58806	VW3-A58825	–
VW3-A58306	VW3-A58407	VW3-A66412	Integrated	–	VW3-A58737	VW3-A58806	VW3-A58825	–
VW3-A58306	VW3-A58408	VW3-A66413	Integrated	–	VW3-A66704	VW3-A58807	VW3-A58826	–
VW3-A58306	VW3-A58407	VW3-A66413	Integrated	–	VW3-A58737	VW3-A58806	VW3-A58825	–
VW3-A58306	VW3-A58408	VW3-A66413	Integrated	–	VW3-A66704	VW3-A58807	VW3-A58826	–
VW3-A58306	VW3-A58408	VW3-A66413	Integrated	–	VW3-A66704	VW3-A58807	VW3-A58826	–
VW3-A58306	VW3-A58408	VW3-A66413	Integrated	–	VW3-A66704	VW3-A58807	VW3-A58826	–
VW3-A58306	VW3-A58408	VW3-A66413	Integrated	–	VW3-A66704	VW3-A58807	VW3-A58826	–

Variable speed controllers for asynchronous motors

Altivar 58
with heatsink

Possible combinations (continued)

Compatibility without integrated EMC filters (see page 60132/2)

Supply Supply voltage 50/60 Hz	Motor Power indicated on rating plate		ATV-58 speed controllers for applications		Options	1 communication choke	Remote or extension card	Programming operator terminal	terminal (1)	
	kW	HP	with standard	with high torque (120 % Tn)	Line torque (170 % Tn)					
208...240 V 3-phase	11	15	–	ATV-58HD16M2X	Integrated	VW3-A58●●●	VW3-A58103	VW3-A58102L●		
	15	20	–	ATV-58HD23M2X	Integrated	VW3-A58●●●	VW3-A58103	VW3-A58102L●		
				ATV-58HD16M2X	–	Integrated	VW3-A58●●●	VW3-A58103	VW3-A58102L●	
	18.5	25	–	ATV-58HD28M2X	Integrated	VW3-A58●●●	VW3-A58103	VW3-A58102L●		
				ATV-58HD23M2X	–	Integrated	VW3-A58●●●	VW3-A58103	VW3-A58102L●	
	22	30	–	ATV-58HD33M2X	Integrated	VW3-A58●●●	VW3-A58103	VW3-A58102L●		
				ATV-58HD28M2X	–	Integrated	VW3-A58●●●	VW3-A58103	VW3-A58102L●	
	30	40	–	ATV-58HD46M2X	Integrated	VW3-A58●●●	VW3-A58103	VW3-A58102L●		
				ATV-58HD33M2X	–	Integrated	VW3-A58●●●	VW3-A58103	VW3-A58102L●	
	37	50	–	ATV-58HD46M2X	–	Integrated	VW3-A58●●●	VW3-A58103	VW3-A58102L●	
	380...500 V 3-phase	18.5	25	–	ATV-58HD28N4X	Integrated	VW3-A58●●●	VW3-A58103	VW3-A58102L●	
		22	30	–	ATV-58HD33N4X	Integrated	VW3-A58●●●	VW3-A58103	VW3-A58102L●	
				ATV-58HD28N4X	–	Integrated	VW3-A58●●●	VW3-A58103	VW3-A58102L●	
30		40	–	ATV-58HD46N4X	Integrated	VW3-A58●●●	VW3-A58103	VW3-A58102L●		
				ATV-58HD33N4X	–	Integrated	VW3-A58●●●	VW3-A58103	VW3-A58102L●	
37		50	–	ATV-58HD54N4X	Integrated	VW3-A58●●●	VW3-A58103	VW3-A58102L●		
				ATV-58HD46N4X	–	Integrated	VW3-A58●●●	VW3-A58103	VW3-A58102L●	
45		60	–	ATV-58HD64N4X	Integrated	VW3-A58●●●	VW3-A58103	VW3-A58102L●		
				ATV-58HD54N4X	–	Integrated	VW3-A58●●●	VW3-A58103	VW3-A58102L●	
55		75	–	ATV-58HD79N4X	Integrated	VW3-A58●●●	VW3-A58103	VW3-A58102L●		
				ATV-58HD64N4X	–	Integrated	VW3-A58●●●	VW3-A58103	VW3-A58102L●	
75		100	–	ATV-58HD79N4X	–	Integrated	VW3-A58●●●	VW3-A58103	VW3-A58102L●	

(1) Reference to be completed according to the language required : 1 for English, Spanish and French ; 2 for German, English and Italian.

PC interconnection	RS 485 interconnection	Additional input filter	Output filter	Braking module	IP 30 braking resistor	Kit for mounting IP 23 air exchanger	Control card fan kit
See p. 60138/3	See p. 60138/3	See p. 60143/3	See p. 60144/3	See p. 60141/4	See p. 60141/5	See p. 60132/5	See p. 60132/6
VW3-A58104	VW3-A58306	VW3-A58407	VW3-A66412	Integrated	VW3-A66704	VW3-A58806	VW3-A58825
VW3-A58104	VW3-A58306	VW3-A58407	VW3-A66412	Integrated	VW3-A66704	VW3-A58806	VW3-A58825
VW3-A58104	VW3-A58306	VW3-A58407	VW3-A66413	Integrated	VW3-A66704	VW3-A58806	VW3-A58825
VW3-A58104	VW3-A58306	VW3-A58408	VW3-A66413	Integrated	VW3-A66704	VW3-A58807	VW3-A58826
VW3-A58104	VW3-A58306	VW3-A58407	VW3-A66413	Integrated	VW3-A66704	VW3-A58806	VW3-A58825
VW3-A58104	VW3-A58306	VW3-A58408	VW3-A66413	Integrated	VW3-A66704	VW3-A58807	VW3-A58826
VW3-A58104	VW3-A58306	VW3-A58408	–	Integrated	VW3-A66704	VW3-A58807	VW3-A58826
VW3-A58104	VW3-A58306	VW3-A58408	–	Integrated	VW3-A66704	VW3-A58807	VW3-A58826
VW3-A58104	VW3-A58306	VW3-A58408	–	Integrated	VW3-A66704	VW3-A58807	VW3-A58826
VW3-A58104	VW3-A58306	VW3-A58406	VW3-A66412	Integrated	VW3-A58737	VW3-A58806	VW3-A58825
VW3-A58104	VW3-A58306	VW3-A58407	VW3-A66412	Integrated	VW3-A58737	VW3-A58806	VW3-A58825
VW3-A58104	VW3-A58306	VW3-A58406	VW3-A66412	Integrated	VW3-A58737	VW3-A58806	VW3-A58825
VW3-A58104	VW3-A58306	VW3-A58407	VW3-A66412	Integrated	VW3-A58737	VW3-A58806	VW3-A58825
VW3-A58104	VW3-A58306	VW3-A58407	VW3-A66412	Integrated	VW3-A58737	VW3-A58806	VW3-A58825
VW3-A58104	VW3-A58306	VW3-A58408	VW3-A66413	Integrated	VW3-A66704	VW3-A58807	VW3-A58826
VW3-A58104	VW3-A58306	VW3-A58407	VW3-A66413	Integrated	VW3-A58737	VW3-A58806	VW3-A58825
VW3-A58104	VW3-A58306	VW3-A58408	VW3-A66413	Integrated	VW3-A66704	VW3-A58807	VW3-A58826
VW3-A58104	VW3-A58306	VW3-A58408	VW3-A66413	Integrated	VW3-A66704	VW3-A58807	VW3-A58826
VW3-A58104	VW3-A58306	VW3-A58408	VW3-A66413	Integrated	VW3-A66704	VW3-A58807	VW3-A58826
VW3-A58104	VW3-A58306	VW3-A58408	VW3-A66413	Integrated	VW3-A66704	VW3-A58807	VW3-A58826
VW3-A58104	VW3-A58306	VW3-A58408	–	Integrated	VW3-A66704	VW3-A58807	VW3-A58826

Variable speed controllers for asynchronous motors

Altivar 58
with sink on baseplate

Possible compatibility

Compatibility with integrated EMC filters (see page 60132/4)

Supply Supply voltage 50/60 Hz	Motor Power indicated on rating plate		ATV-58 speed controllers for app.		Options				
	kW	HP	standard torque (120 % Cn)	high torque (170 % Cn)	Line choke See p. 60142/3	1 extension or communication card See p. 60139/3 See p. 60140/3	Remote operator terminal See p. 60138/2	Programming terminal (1) See p. 60138/2	PC interconnection See p. 60138/3
200...240 V single phase	0.37	0.5	–	ATV-58PU09M2	VZ1-L004M010	VW3-A58●●●	VW3-A58103	VW3-A58102L●	VW3-A58104
	0.75	1	–	ATV-58PU18M2	VZ1-L007UM50	VW3-A58●●●	VW3-A58103	VW3-A58102L●	VW3-A58104
	1.5	2	–	ATV-58PU29M2	VZ1-L018UM20	VW3-A58●●●	VW3-A58103	VW3-A58102L●	VW3-A58104
	2.2	3	–	ATV-58PU41M2	VZ1-L018UM20	VW3-A58●●●	VW3-A58103	VW3-A58102L●	VW3-A58104
	3	–	–	ATV-58PU72M2	VW3-A58501	VW3-A58●●●	VW3-A58103	VW3-A58102L●	VW3-A58104
	4	5	–	ATV-58PU90M2	VW3-A58502	VW3-A58●●●	VW3-A58103	VW3-A58102L●	VW3-A58104
	5.5	7.5	–	ATV-58PD12M2	VW3-A58502	VW3-A58●●●	VW3-A58103	VW3-A58102L●	VW3-A58104
200...240 V 3-phase	1.5	2	–	ATV-58PU29M2	VW3-A66502	VW3-A58●●●	VW3-A58103	VW3-A58102L●	VW3-A58104
	2.2	3	–	ATV-58PU41M2	VW3-A66503	VW3-A58●●●	VW3-A58103	VW3-A58102L●	VW3-A58104
	3	–	–	ATV-58PU54M2	VW3-A66503	VW3-A58●●●	VW3-A58103	VW3-A58102L●	VW3-A58104
	4	5	–	ATV-58PU72M2	VW3-A66504	VW3-A58●●●	VW3-A58103	VW3-A58102L●	VW3-A58104
	5.5	7.5	–	ATV-58PU90M2	VW3-A66504	VW3-A58●●●	VW3-A58103	VW3-A58102L●	VW3-A58104
	7.5	10	–	ATV-58PD12M2	VW3-A66504	VW3-A58●●●	VW3-A58103	VW3-A58102L●	VW3-A58104
380...500 V 3-phase	0.75	1	–	ATV-58PU18N4	VW3-A66501	VW3-A58●●●	VW3-A58103	VW3-A58102L●	VW3-A58104
	1.5	2	–	ATV-58PU29N4	VW3-A66501	VW3-A58●●●	VW3-A58103	VW3-A58102L●	VW3-A58104
	2.2	3	–	ATV-58PU41N4	VW3-A66502	VW3-A58●●●	VW3-A58103	VW3-A58102L●	VW3-A58104
	3	–	–	ATV-58PU54N4	VW3-A66502	VW3-A58●●●	VW3-A58103	VW3-A58102L●	VW3-A58104
	4	5	–	ATV-58PU72N4	VW3-A66502	VW3-A58●●●	VW3-A58103	VW3-A58102L●	VW3-A58104
	5.5	7.5	–	ATV-58PU90N4	VW3-A66503	VW3-A58●●●	VW3-A58103	VW3-A58102L●	VW3-A58104
	7.5	10	–	ATV-58PD12N4	VW3-A66503	VW3-A58●●●	VW3-A58103	VW3-A58102L●	VW3-A58104
	11	15	–	ATV-58PD16N4	VW3-A66504	VW3-A58●●●	VW3-A58103	VW3-A58102L●	VW3-A58104
15	20	–	ATV-58PD23N4	VW3-A66504	VW3-A58●●●	VW3-A58103	VW3-A58102L●	VW3-A58104	

(1) Reference to be completed according to the language required : 1 for English, Spanish and French ; 2 for German, English and Italian.

RS 485 interconnection	Additional input filter	Output filter	Braking module	IP 00 braking resistor	IP 30 braking resistor	Kit for mounting in IP 54 enclosure	Control card fan kit	Plug-in power terminal block
See p. 60138/3	See p. 60143/3	See p. 60144/3	See p. 60141/4	See p. 60141/4	See p. 60141/5	See p. 60132/5	See p. 60132/6	See p. 60132/7
VW3-A58306	VW3-A58401	–	VW3-A58701	VW3-A58702	VW3-A58732	–	VW3-A58821	VW3-A58811
VW3-A58306	VW3-A58401	VW3-A58451	VW3-A58701	VW3-A58702	VW3-A58732	–	VW3-A58821	VW3-A58811
VW3-A58306	VW3-A58402	VW3-A58451	Integrated	VW3-A58702	VW3-A58732	VW3-A58802	VW3-A58822	VW3-A58812
VW3-A58306	VW3-A58402	VW3-A58452	Integrated	VW3-A58704	VW3-A58733	VW3-A58802	VW3-A58822	VW3-A58812
VW3-A58306	VW3-A58403	VW3-A58452	Integrated	–	VW3-A58736	VW3-A58803	VW3-A58823	VW3-A58813
VW3-A58306	VW3-A58404	VW3-A58452	Integrated	–	VW3-A58737	VW3-A58804	VW3-A58824	–
VW3-A58306	VW3-A58404	VW3-A58453	Integrated	–	VW3-A58737	VW3-A58804	VW3-A58824	–
VW3-A58306	VW3-A58402	VW3-A58451	Integrated	VW3-A58702	VW3-A58732	VW3-A58802	VW3-A58822	VW3-A58812
VW3-A58306	VW3-A58402	VW3-A58452	Integrated	VW3-A58704	VW3-A58733	VW3-A58802	VW3-A58822	VW3-A58812
VW3-A58306	VW3-A58403	VW3-A58452	Integrated	VW3-A58704	VW3-A58733	VW3-A58803	VW3-A58823	VW3-A58813
VW3-A58306	VW3-A58403	VW3-A58452	Integrated	–	VW3-A58736	VW3-A58803	VW3-A58823	VW3-A58813
VW3-A58306	VW3-A58404	VW3-A58452	Integrated	–	VW3-A58737	VW3-A58804	VW3-A58824	–
VW3-A58306	VW3-A58404	VW3-A58453	Integrated	–	VW3-A58737	VW3-A58804	VW3-A58824	–
VW3-A58306	VW3-A58402	VW3-A58451	Integrated	VW3-A58702	VW3-A58732	VW3-A58802	VW3-A58822	VW3-A58812
VW3-A58306	VW3-A58402	VW3-A58451	Integrated	VW3-A58702	VW3-A58732	VW3-A58802	VW3-A58822	VW3-A58812
VW3-A58306	VW3-A58402	VW3-A58451	Integrated	VW3-A58702	VW3-A58732	VW3-A58802	VW3-A58822	VW3-A58812
VW3-A58306	VW3-A58403	VW3-A58451	Integrated	VW3-A58703	VW3-A58734	VW3-A58803	VW3-A58823	VW3-A58813
VW3-A58306	VW3-A58403	VW3-A58451	Integrated	VW3-A58703	VW3-A58734	VW3-A58803	VW3-A58823	VW3-A58813
VW3-A58306	VW3-A58403	VW3-A58452	Integrated	–	VW3-A58735	VW3-A58803	VW3-A58823	VW3-A58813
VW3-A58306	VW3-A58404	VW3-A58452	Integrated	–	VW3-A58735	VW3-A58804	VW3-A58824	–
VW3-A58306	VW3-A58404	VW3-A58452	Integrated	–	VW3-A58736	VW3-A58804	VW3-A58824	–
VW3-A58306	VW3-A58405	VW3-A58453	Integrated	–	VW3-A58736	VW3-A58805	VW3-A58824	–

Variable speed controllers for asynchronous motors

Presentation :
pages 60131/2 to 60131/6
Characteristics :
pages 60131/7 to 60131/9
Dimensions, schemes :
pages 60134/2 to 60135/8
Functions :
pages 60133/2 to 60133/25

Altivar 58
with integrated heatsink and EMC filters
for asynchronous motors from 0.37 to 75 kW or 0.5 to 100 HP

References

High torque applications (170 % Tn)



ATV-58HU18M2

Motor Power indicated on rating plate (1)	Mains supply Line current (2)		Max.prospective line Isc		Altivar 58 Max. speed controller nominal current (3)		Max. transient current (4)	Power dissipated at nominal load (4)	Reference (5)	Weight
	U min	U max	U min	U max	A	A				
kW	HP	A	A	kA	kA	A	A	W		kg

Single phase supply voltage : 200...240 V (6) 50/60 Hz

0.37	0.5	5.6	4.7	2	2	2.3	3.1	42	ATV-58HU09M2	2.200
0.75	1	9.8	8.3	2	2	4.1	5.6	64	ATV-58HU18M2	2.200
1.5	2	18.5	15.6	5	5	7.8	10.6	107	ATV-58HU29M2	3.800
2.2	3	24.8	21.1	5	5	11	15	145	ATV-58HU41M2	3.800
3	-	24.7	21.3	5	5	13.7	18.6	220	ATV-58HU72M2 (7)	6.900
4	5	35	30	22	22	18.2	24.7	235	ATV-58HU90M2 (7)	13.000
5.5	7.5	46	39.4	22	22	24.2	32.9	310	ATV-58HD12M2 (7)	13.000

3-phase supply voltage : 200...240 V (6) 50/60 Hz

1.5	2	9.7	8.3	5	5	7.8	10.6	107	ATV-58HU29M2	3.800
2.2	3	13.4	11.4	5	5	11	15	145	ATV-58HU41M2	3.800
3	-	17.2	15	5	5	13.7	18.6	170	ATV-58HU54M2	6.900
4	5	22.4	19.5	5	5	18.2	24.7	220	ATV-58HU72M2	6.900
5.5	7.5	34.7	30	22	22	24.2	32.9	235	ATV-58HU90M2	13.000
7.5	10	44.4	38.2	22	22	31	42.2	310	ATV-58HD12M2	13.000

3-phase supply voltage : 380...500 V (6) 50/60 Hz

0.75	1	3.4	2.6	5	5	2.3	3.1	55	ATV-58HU18N4	3.800
1.5	2	6	4.5	5	5	4.1	5.6	65	ATV-58HU29N4	3.800
2.2	3	7.8	6	5	5	5.8	7.9	105	ATV-58HU41N4	3.800
3	-	10.2	7.8	5	5	7.8	10.6	145	ATV-58HU54N4	6.900
4	5	13	10.1	5	5	10.5	14.3	180	ATV-58HU72N4	6.900
5.5	7.5	17	13.2	5	5	13	17.7	220	ATV-58HU90N4	6.900
7.5	10	26.5	21	22	22	17.6	24	230	ATV-58HD12N4	13.000
11	15	35.4	28	22	22	24.2	32.9	340	ATV-58HD16N4	13.000
15	20	44.7	35.6	22	22	33	44.9	410	ATV-58HD23N4	15.000
18.5	25	43	35	22	65	41	55	670	ATV-58HD28N4	34.000
22	30	51	41	22	65	48	66	780	ATV-58HD33N4	34.000
30	40	68	55	22	65	66	90	940	ATV-58HD46N4	34.000
37	50	82	66	22	65	79	108	940	ATV-58HD54N4	57.000
45	60	101	82	22	65	94	127	1100	ATV-58HD64N4	57.000
55	75	121	98	22	65	116	157	1475	ATV-58HD79N4	57.000

Standard torque applications (120 % Tn)

3-phase supply voltage : 380...500 V (6) 50/60 Hz

22	30	51	41	22	65	44	55	750	ATV-58HD28N4	34.000
30	40	67	53	22	65	60	66	925	ATV-58HD33N4	34.000
37	50	82	66	22	65	72	90	1040	ATV-58HD46N4	34.000
45	60	99	79	22	65	85	108	1045	ATV-58HD54N4	57.000
55	75	121	97	22	65	105	127	1265	ATV-58HD64N4	57.000
75	100	160	130	22	65	138	157	1730	ATV-58HD79N4	57.000

(1) These powers are given for the maximum switching frequency permitted by the speed controller (2 or 4 kHz depending on rating), in continuous operation with no derating. For higher switching frequencies, the controller must be in intermittent operation or the speed controller must be set one rating lower. See special uses on the previous pages.

(2) Typical value without additional choke for a 4-pole motor. Exceptions : ATV-58HU72M2, HU90M2 and HD12M2 (single phase) (7).

(3) For 60 seconds.

(4) These powers are given for the maximum switching frequency permitted by the speed controller in continuous operation (2 or 4 kHz depending on rating).

(5) Speed controller supplied with an operator terminal mounted on it. To obtain a speed controller without an operator terminal, add the letter **Z** at the end of the reference.

Example : **ATV-58HU09M2** without operator terminal, the reference is **ATV-58HU09M2Z**.

(6) Nominal supply voltage, U min...U max.

(7) A line choke must be used if these speed controllers are connected to a single phase supply.



ATV-58HD54N4

Variable speed controllers for asynchronous motors

Presentation :
pages 60131/2 to 60131/6
Characteristics :
pages 60131/7 to 60131/9
Dimensions, schemes :
pages 60134/2 to 60135/8
Functions :
pages 60133/2 to 60133/25

Altivar 58
with integrated heatsink and no EMC filters
for asynchronous motors from 11 to 75 kW or 15 to 100 HP

References

High torque applications (170 % Tn)



ATV-58HD28N4X

Motor Power indicated on rating plate (1)	Mains supply Line current (2) at U min	at U max	Max.prospective line Isc		Altivar 58 Speed controller nominal current		Max. transient current (3)	Power dissipated at nominal load (4)	Reference (5)	Weight
			U min	U max	kA	kA				
kW	HP	A	A	kA	kA	A	A	W		kg

3-phase supply voltage : 208...240 V (6) 50/60 Hz

11	15	43	40	10	22	47	64	745	ATV-58HD16M2X	34.000
15	20	59	54	10	22	60	82	900	ATV-58HD23M2X	34.000
18.5	25	71	64	10	22	75	102	895	ATV-58HD28M2X	57.000
22	30	84	78	10	22	88	120	1030	ATV-58HD33M2X	57.000
30	40	115	104	10	22	116	158	1315	ATV-58HD46M2X	57.000

3-phase supply voltage : 380...500 V (6) 50/60 Hz

18.5	25	43	35	22	65	41	55	660	ATV-58HD28N4X	34.000
22	30	51	41	22	65	48	66	775	ATV-58HD33N4X	34.000
30	40	68	55	22	65	66	90	925	ATV-58HD46N4X	34.000
37	50	82	66	22	65	79	108	930	ATV-58HD54N4X	57.000
45	60	101	82	22	65	94	127	1085	ATV-58HD64N4X	57.000
55	75	121	98	22	65	116	157	1455	ATV-58HD79N4X	57.000

Standard torque applications (120 % Tn)

3-phase supply voltage : 208...240 V (6) 50/60 Hz

15	20	58	52	10	22	60	64	890	ATV-58HD16M2X	34.000
18.5	25	70	63	10	22	75	82	980	ATV-58HD23M2X	34.000
22	30	82	74	10	22	88	102	975	ATV-58HD28M2X	57.000
30	40	114	102	10	22	116	120	1215	ATV-58HD33M2X	57.000
37	50	141	125	10	22	143	158	1610	ATV-58HD46M2X	57.000

3-phase supply voltage : 380...500 V (6) 50/60 Hz

22	30	51	41	22	65	44	55	735	ATV-58HD28N4X	34.000
30	40	67	53	22	65	60	66	915	ATV-58HD33N4X	34.000
37	50	82	66	22	65	72	90	1020	ATV-58HD46N4X	34.000
45	60	99	79	22	65	85	108	1030	ATV-58HD54N4X	57.000
55	75	121	97	22	65	105	127	1245	ATV-58HD64N4X	57.000
75	100	160	130	22	65	138	157	1700	ATV-58HD79N4X	57.000

(1) These powers are given for the maximum switching frequency permitted by the speed controller (2 or 4 kHz depending on rating), in continuous operation with no derating. For higher switching frequencies, the controller must be in intermittent operation or the speed controller must be set one rating lower. See special uses on the previous pages.

(2) Typical value for a 4-pole motor.

(3) For 60 seconds.

(4) These powers are given for the maximum switching frequency permitted by the speed controller in continuous operation (2 or 4 kHz depending on rating).

(5) Speed controller supplied with an operator terminal mounted on it. To obtain a speed controller without an operator terminal, add the letter **Z** at the end of the reference.

Example : **ATV-58HD16M2X** without operator terminal, the reference is **ATV-58HD16M2XZ**.

(6) Nominal supply voltage, U min...U max.



ATV-58HD54N4X

Variable speed controllers for asynchronous motors

Presentation :
pages 60131/2 to 60131/6
Characteristics :
pages 60131/7 to 60131/9
Dimensions, schemes :
pages 60134/2 to 60135/8
Functions :
pages 60133/2 to 60133/25

Altivar 58
on baseplate and with integrated EMC filters
for asynchronous motors from 0.37 to 15 kW or 0.5 to 20 HP

References

High torque applications (170 % Tn)



ATV-58PU18M2

Motor Power indicated on rating plate (1)	Mains supply Line current (2)				Altivar 58 Speed controller nominal current (3)				Max. transient current at nominal load (4)	Reference (5)	Weight kg
	at U min	at U max	Max.prospective line Isc at U min	at U max	A	A	A	A			
kW	HP	A	A	kA	kA	A	A	W			
Single phase supply voltage : 200...240 V (6) 50/60 Hz											
0.37	0.5	5.6	4.7	2	2	2.3	3.1	25		ATV-58PU09M2	1.800
0.75	1	9.8	8.3	2	2	4.1	5.6	30		ATV-58PU18M2	1.800
1.5	2	18.5	15.6	5	5	7.8	10.6	40		ATV-58PU29M2	2.900
2.2	3	24.8	21.1	5	5	11	15	50		ATV-58PU41M2	2.900
3	–	24.7	21.3	5	5	13.7	18.6	70		ATV-58PU72M2 (7)	4.800
4	5	35	30	22	22	18.2	24.7	75		ATV-58PU90M2 (7)	11.500
5.5	7.5	46	39.4	22	22	24.2	32.9	100		ATV-58PD12M2 (7)	11.500
3-phase supply voltage : 200...240 V (6) 50/60 Hz											
1.5	2	9.7	8.3	5	5	7.8	10.6	40		ATV-58PU29M2	2.900
2.2	3	13.4	11.4	5	5	11	15	50		ATV-58PU41M2	2.900
3	–	17.2	15	5	5	13.7	18.6	60		ATV-58PU54M2	4.800
4	5	22.4	19.5	5	5	18.2	24.7	70		ATV-58PU72M2	4.800
5.5	7.5	34.7	30	22	22	24.2	32.9	75		ATV-58PU90M2	11.500
7.5	10	44.4	38.2	22	22	31	42.2	100		ATV-58PD12M2	11.500
3-phase supply voltage : 380...500 V (6) 50/60 Hz											
0.75	1	3.4	2.6	5	5	2.3	3.1	35		ATV-58PU18N4	2.900
1.5	2	6	4.5	5	5	4.1	5.6	40		ATV-58PU29N4	2.900
2.2	3	7.8	6	5	5	5.8	7.9	50		ATV-58PU41N4	2.900
3	–	10.2	7.8	5	5	7.8	10.6	55		ATV-58PU54N4	4.800
4	5	13	10.1	5	5	10.5	14.3	65		ATV-58PU72N4	4.800
5.5	7.5	17	13.2	5	5	13	17.7	80		ATV-58PU90N4	4.800
7.5	10	26.5	21	22	22	17.6	24	90		ATV-58PD12N4	11.500
11	15	35.4	28	22	22	24.2	32.9	110		ATV-58PD16N4	11.500
15	20	44.7	35.6	22	22	33	44.9	140		ATV-58PD23N4	13.500

(1) These powers are given for the maximum switching frequency permitted by the speed controller (2 or 4 kHz depending on rating), in continuous operation with no derating. For higher switching frequencies, the controller must be in intermittent operation or the speed controller must be set one rating lower. See special uses on the previous pages.

(2) Typical value without additional choke for a 4-pole motor. Exceptions : ATV-58PU72M2, 58PU90M2 and 58PD12M2 (single phase) (7).

(3) For 60 seconds.

(4) These powers are given for the maximum switching frequency permitted by the speed controller in continuous operation (2 or 4 kHz depending on rating).

(5) Speed controller supplied with an operator terminal mounted on it. To obtain a speed controller without an operator terminal, add the letter **Z** at the end of the reference.

Example : **ATV-58PU09M2** without operator terminal, the reference is **ATV-58PU09M2Z**.

(6) Nominal supply voltage, U min...U max.

(7) A line choke must be used if these speed controllers are connected to a single phase supply.

Variable speed controllers for asynchronous motors

Altivar 58 Accessories

Presentation
pages 60131/2 to 60131/6
Dimensions :
page 60134/4

References

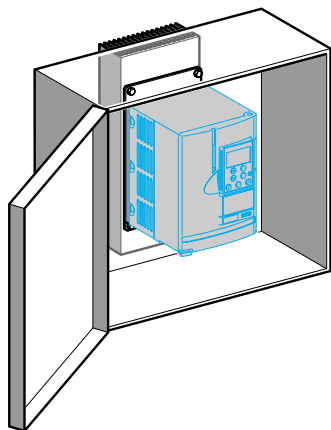

VW3-A5880●

Kit for mounting in dust and damp proof enclosures (degree of protection IP 54)

This kit can be used for mounting the speed controller on a baseplate inside a dust and damp proof enclosure, evacuating heat via an externally mounted heatsink. The only work to be done on the enclosure involves drilling the fixing holes. The kit consists of :

- Sealing joints.
- A heatsink.
- A set of instructions.

The ATV-58PU09M2 and 58PU18M2 are not affected, as the power dissipated by the models to the heatsink is low enough to allow these ratings to be mounted in an enclosure, (the ATV-58PU09M2 and 58PU18M2 are the only ones to be mounted directly on the machine frame).

Characteristics of the enclosure

The surface of the cabinet or enclosure used for mounting the speed controller must have the following characteristics :

- Thickness 1.5 to 3 mm.
- Metal sheet : stainless or painted steel, adequately smooth.
- Heat-treated epoxy paintwork (do not use lacquer), max thickness 70 µm, fine or medium texture.

For speed controllers	Reference	Weight kg
ATV-58PU29M2, PU41M2, PU18N4, PU29N4, PU41N4	VW3-A58802	3.800
ATV-58PU54M2, PU72M2, PU54N4, PU72N4, PU90N4	VW3-A58803	8.300
ATV-58PU90M2, PD12M2, PD12N4, PD16N4	VW3-A58804	6.000
ATV-58PD23N4	VW3-A58805	7.600

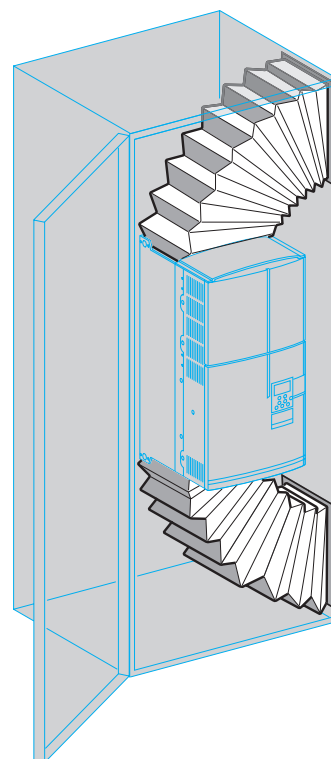

VW3-A5880●

Kit for mounting "air exchanger" with outside (degree of protection IP 23)

This kit can be used for mounting certain speed controllers with heatsinks (ATV-58HD●●M2X, HD28N4 to HD79N4 and HD28N4X to HD79N4X) inside a dust and damp proof enclosure, evacuating heat with fittings which allow the fan to draw cold air into the lower section, and to eliminate hot air to the outside from the upper section. This requires two cut-outs of enclosure.

The mounting kit consists of :

- 2 bellows (max length = 1 m).
- 2 grilles.
- 1 set of instructions.

For speed controllers	Reference	Weight kg
ATV-58HD16M2X, HD23M2X ATV-58HD28N4, HD33N4, HD46N4 ATV-58HD28N4X, HD33N4X, HD46N4X	VW3-A58806	4.000
ATV-58HD28M2X, HD33M2X, HD46M2X ATV-58HD54N4, HD64N4, HD79N4 ATV-58HD54N4X, HD64N4X, HD79N4X	VW3-A58807	5.000

Variable speed controllers for asynchronous motors

Altivar 58
Accessories

Presentation :
pages 60131/2 to 60131/6
Dimensions :
page 60134/4

References (continued)

Control card fan kit



VW3-A58823

This fan kit enables the speed controller to operate at an ambient temperature of 60 °C, eg. in the case of mounting in an IP 54 enclosure. The circulation of air around the electronic cards prevents the formation of hot spots.

This kit is fixed to the upper part of the speed controller. It is also powered by the speed controller.

The kit consists of :

- A fan subassembly
- Mounting accessories
- A set of instructions.

For speed controllers	Reference	Weight kg
ATV-58●U09M2, ●U18M2	VW3-A58821	0.350
ATV-58●U29M2, ●U41M2, ●U18N4, ●U29N4, ●U41N4	VW3-A58822	0.450
ATV-58●U54M2, ●U72M2, ●U54N4, ●U72N4, ●U90N4	VW3-A58823	0.450
ATV-58●U90M2, ●D12M2, ●D12N4, ●D16N4, ●D23N4	VW3-A58824	0.500
ATV-58HD16M2X, HD23M2X ATV-58HD28N4, HD33N4, HD46N4 ATV-58HD28N4X, HD33N4X, HD46N4X	VW3-A58825	1.200
ATV-58HD28M2X, HD33M2X, HD46M2X ATV-58HD54N4, HD64N4, HD79N4 ATV-58HD54N4X, HD64N4X, HD79N4X	VW3-A58826	1.200

Variable speed controllers for asynchronous motors

Altivar 58
Options : dialogue

References (continued)

Presentation :
pages 60131/2 to 60131/6

PC interconnection add-on

The PC interconnection add-on is used to establish a link between the Altivar 58 or the programming terminal and a PC with a Microsoft Windows version 3.1. or Windows 95 or 98 environment.

Description	For speed controllers	Reference	Weight kg
Complete PC interconnection add-on comprising : <ul style="list-style-type: none">- a connecting cable, length 3 m with two 9-way SUB-D connectors- an RS 485/RS 232C adaptor- 3" 1/2 diskettes, capacity 1.44 Mb- manual	Altivar 58 all ratings	VW3-A58104	0.250
Software only with 3" 1/2 diskettes, capacity 1.44 Mb	Altivar 58 all ratings	VW3-A58105	0.150

RS 485 connection kit

This kit is used for RS 485 multidrop serial link connection to PLCs, man-machine interface terminals, etc. It is connected in place of the operator terminal and cannot therefore be used at the same time.

Description	For speed controllers	Reference	Weight kg
RS 485 connection kit comprising : <ul style="list-style-type: none">- 1 cable, length 3 m with 1 male 9-way SUB-D connector and 1 male 15-way SUB-D connector- manual	Altivar 58 all ratings	VW3-A58306	0.200

Variable speed controllers for asynchronous motors

Altivar 58

Options : I/O extension cards, customer-specific cards

Presentation, characteristics

Schemes :
pages 60135/6 and 60135/7

Presentation

I/O extension cards

The Altivar 58 speed controller can be specially adapted to suit certain types of application by installing an I/O extension card in the speed controller. Two models are available :

- **Card with analogue input**

Includes two ± 24 V logic inputs, one ± 24 V open collector logic output, one 0/20 mA analogue output and one bipolar ± 10 V analogue input. The analogue input can be used for speed correction with a tachogenerator, for feedback of the PI function, for processing of PTC motor protection probes or for summing the frequency reference.

- **Card with encoder inputs**

Includes two a 24 V logic inputs, one a 24 V open collector logic output, one 0/20 mA analogue output and A+, A-, B+, B- inputs which can be used for speed correction with an incremental encoder (Telemecanique XCC-H for example) or with an inductive or photoelectric sensor.

Customer-specific cards

To meet the requirements of special applications for which neither the standard product nor I/O extension cards are suitable, we can design and supply cards on request which incorporate :

- hardware functions (I/O)
- software functions, (special cycles and servo controls, etc)

Cards are already available for :

pump switching, multimotor operation and multiparameter entry.

- **Pump switching card**

This is used for controlling a complete pumping or compression installation using a single Altivar 58, and provides :

- constant pressure in the supply, regardless of flow rate,
- ease of setup and diagnosis of the installation, using the Altivar 58,
- control of a variable speed pump and up to 4 fixed speed pumps, avoiding systematic wear of the same pumps. For more information, please consult you Regional Sales Office.

- **Multimotor card**

Has 2 ± 24 V reassignable logic inputs, 1 ± 24 V open collector logic output, one 0/20 mA analogue output, and one bipolar ± 10 V analogue input. The analogue input can be used for speed correction with a tachogenerator, for feedback of the PI function, for processing of PTC motor protection probes, or for summing the frequency reference. Two speed controller configurations can be switched when the motor is stopped.

Functions :

Loading two configurations with an Altivar 58 operator dialogue terminal, switching configurations via logic input or with an operator dialogue terminal, automatic auto-tuning possible after switching.

- **Multiparameter entry card**

It enables up to 8 sets of 27 pre-defined parameters to be switched automatically or via logic input, when the motor is running.

The Altivar 58 is designed to take a card mounted in the I/O extension card slot.

These special cards are for use with standard machines. Please consult your Regional Sales Office for a quotation.

Characteristics of I/O extension cards

Available internal supplies	Protected against short-circuits and overloads - 1 output + 10 V ± 1 %, max current 10 mA - 1 output - 10 V ± 1 %, max current 10 mA - 1 output + 24 V (min 20 V, max 30 V), maximum current 200 mA for all 24 V outputs on the speed controller
Logic inputs LI	Assignable logic inputs with impedance 3.5 k Ω , compatible with level 1 PLC, standard IEC 65A-68 Maximum length of shielded cable : 100 m Power supply + 24 V (min 12 V, max 30 V). State 0 if < 5 V, state 1 if > 11 V Sampling time 2 ms maximum
Logic output LO	Assignable open collector logic output, compatible with level 1 PLC, standard IEC 65A-68 Power supply + 24 V (min 12 V, max 30 V), max current 20 mA with internal supply and 200 mA with external supply Sampling time 2 ms maximum
Analogue output AO	Assignable analogue output 0/20 mA, max load impedance 500 Ω (reassignable to X-YmA, by programming X and Y from 0 to 20 with a definition of 0.1 mA) Resolution 0.04 mA (9-bit), linearity ± 0.1 mA, precision ± 0.2 mA Sampling time 2 ms maximum
Analogue input AI	1 assignable bipolar differential input 0 ± 10 V, impedance 30 k Ω . Adjustable gain Frequency reference resolution : 0.1 Hz for 100 Hz (10 bits and sign) Precision ± 0.5 %, linearity ± 0.2 % of the max output frequency Sampling time 2 ms maximum. Max length of shielded cable : 20 m
or	If configured for PTC probe processing, use at 750 Ω max at 20 $^{\circ}$ C (3 x 250 Ω probes in series)
A+, A-, B+, B- logic inputs	For encoders or detectors with NPN-type open collector outputs, nominal voltage 24 V \pm (19.2 to 30 V) Input impedance 785 Ω ± 10 % Maximum frequency of signals 33 kHz at HSP maximum speed We recommend that you use an external 24 V supply when using the speed controller with incremental encoders

Variable speed controllers for asynchronous motors

Altivar 58

Options : communication cards

Presentation, functions, characteristics

Presentation

The Altivar 58 can be adapted for communication by adding a communication card.

6 models are available :

- Fipio,
- Uni-Telway, Modbus ASCII, Modbus RTU/Jbus,
- Interbus-S,
- Modbus Plus,
- AS-i,
- Profibus DP.

Functions

Fipio, Uni-Telway/Modbus, Interbus-S, Modbus Plus, Profibus DP cards

All Altivar 58 functions can be used with these cards :

- **Configuration** (accessible in read and write modes) : mains frequency, motor voltage, ramp profiles, I/O assignment, etc.
- **Adjustments** (accessible in read and write modes) : d.c. injection time and amplitude, thermal protection, speed range, ramp time, current limitation, etc.
- **Control** (accessible in read and write modes) : start/stop, braking, frequency reference, fault reset, etc.
- **Display** (accessible in read only mode) : speed controller status register, motor speed, motor current, logic I/O status register, fault register, etc.
- **Authorisation** of local control (via terminal block).

AS-i card

The following Altivar 58 functions can be used with this card :

- **Control** : start/stop, braking, frequency reference (preset values), fault reset, +/- speed.
- **Display** : speed controller status (ready, running, faulty, frequency reference reached, thermal threshold reached, local forcing).
- **Authorisation** of control via terminal block (local forcing).

Characteristics

Protocols	Fipio	Modbus Plus	Uni-Telway, Modbus ASCII, Modbus RTU/Jbus	Interbus-S	AS-i	Profibus DP
Number of controllers controlled	62	64	31	64	31	127
Transmission speed	1 Mbps	1 Mbps	4800...19 200 bps	1 Mbps	166 Kbps	1.5 Mbps

Variable speed controllers for asynchronous motors

Altivar 58

Options : communication cards

References

Communication cards

Card for protocol	For speed controllers	Reference	Weight kg
<p>Fipio : the card is equipped with a male 9-pin SUB-D connector, which will take a TSX FP ACC2 mobile connector for ATV-58E or TSX FP ACC 12 mobile connector for ATV-58H and ATV-58P with a TSX FP CC●● extension cable or a TSX FP CA●● tap-off cable (see our specialist catalogue).</p>	ATV-58 all ratings	VW3-A58301	0.300
<p>Modbus Plus : the card is equipped with a female 9-pin SUB-D connector, which will take a Modbus Plus tap-off cable equipped with connectors, reference 990NAD21910 or 990NAD21930, to be connected on T-junction box 990NAD23000 for connection to the Modbus Plus main cable reference 490NAA271●● To order Modbus Plus cables and accessories, see our specialist catalogue.</p>	ATV-58 all ratings	VW3-A58302	0.300
<p>Uni-Telway-Modbus : the card is equipped with a female 9-pin SUB-D connector and a 3 m cable equipped with a male 9-pin connector and a male 15-pin connector for connecting to the TSX SCA 62● box (see our specialist catalogue).</p>	ATV-58 all ratings	VW3-A58303	0.300
<p>Interbus-S : the card is equipped with 2 male and female 9-pin SUB-D connectors for connecting to cables equipped with connectors (see manufacturers' catalogue), and 2 screw terminals for separate --- 24 V power supply. Power supply : --- 24 V, 200 mA min to be ordered separately</p>	ATV-58 all ratings	VW3-A58304	0.300
<p>AS-i : the card is equipped with a removable terminal block. For cables and connection accessories, see our specialist catalogue. (for example : use a tap-off for AS-i cable : XZ-CG0122)</p>	ATV-58 all ratings	VW3-A58305	0.300
<p>Profibus DP : the card is equipped with a female 9-pin SUB-D connector for connecting to pre-equipped cables (see manufacturers' catalogue)</p>	ATV-58 all ratings	VW3-A58307	0.300

Note : The communication cards are equipped with terminal blocks or connectors which are compatible with the corresponding communication buses. To connect them, please use the associated PLC accessories.

Variable speed controllers for asynchronous motors

Altivar 58

Options : braking module and resistors

References :
pages 60141/4 and 60141/5
Dimensions :
page 60134/3

Presentation, characteristics

Presentation

The resistor enables the Altivar 58 speed controller to operate when braking to a standstill or during slowdown braking, by dissipating the braking energy.

Presentation

There are two types available :

- a model in an IP 30 or IP 23 unit designed for EMC, protected by a temperature controlled switch or thermal relay.
- an model without protection, for low power ratings only.

Applications

Machines with high inertia, driving loads, machine with fast cycles.

Braking is integrated in the Altivar 58 with the exception of the ATV-58●U09M2 and ATV-58●U18M2 controllers, which require an additional braking module.

Characteristics

References		VW3-A58732 to VW3-A58735	VW3-A58736 and VW3-A58737	VW3-A58702 to VW3-A58704	VW3-A66704
Ambient air temperature	°C	40	40	40	40
Degree of protection of the unit		IP 30	IP 30	IP 00	IP 23
Protection of the resistor		By temperature controlled switch (1)	By temperature controlled switch (1)	None	By thermal relay (1) (2)
Temperature controlled switch					
Tripping temperature	°C	130 ± 5 %	260 ± 14 %	-	-
Max voltage - max current		~ 110 V - 0.3 A	~ 220 V - 6 A	-	-
Min voltage - min current		~ 24 V - 0.01 A	~ 24 V - 0.01 A	-	-
Maximum contact resistance	mΩ	150	50	-	-
Load factor of resistors		The average value of the power which can be dissipated at 40 °C by the resistor in the unit is determined for a load factor during braking which corresponds to most common applications : - 2 seconds braking with a torque of 0.6 Tn every 40 seconds - 0.8 seconds braking with a torque of 1.5 Tn every 40 seconds.			

Braking torque with resistor (speed controller limits)

High torque applications

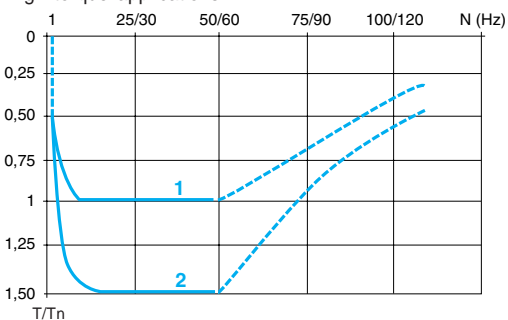

- 1 Continuous braking torque (driving load)
Load factor 100 %.
- 2 Maximum transient braking torque (for 60 s).

Standard torque applications

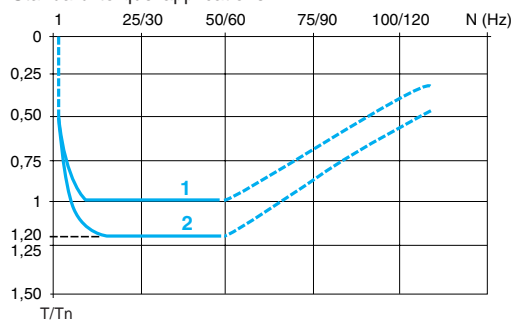

- 1 Continuous braking torque (driving load)
Load factor 100 %.
- 2 Maximum transient braking torque (for 60 s).

Minimum ohmic value of resistors which can be used with ATV-58 speed controller

ATV-58● speed controller	U09M2 U18M2	U29M2 U41M2	U54M2	U72M2	U90M2 D12M2	D16M2X	D23M2X	D28M2X	D33M2X	D46M2X
Min resistance value in ohms	75	38	31	25	13	8	8	4	2.67	2.67
ATV-58● speed controller	U18N4 U29N4 U41N4 U54N4	U72N4	U90N4	D12N4	D16N4 D23N4	D28N4, D28N4X D33N4, D33N4X D46N4, D46N4X	D54N4 D54N4X	D64N4 D64N4X D79N4 D79N4X		
Min resistance value in ohms	85	57	47	53	19	14	8	5		

- (1) The switch must be connected in sequence (use for signalling or to control the line contactor).
- (2) Please order separately, rating 8 A.

Variable speed controllers for asynchronous motors

Altivar 58

Options : braking module and resistors

References :
pages 60141/4 and 60141/5
Dimensions :
page 60134/3

Characteristics (continued)

Load factor

The average value of power which can be dissipated at 40 °C by the resistor in the unit is determined for a load factor when braking, which corresponds to most common applications.

This load factor is given in the table on the previous page.

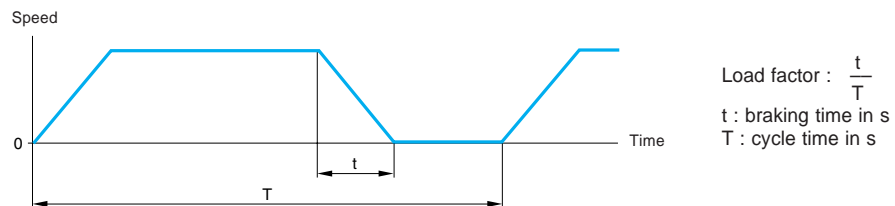

For a specific application (hoisting, materials handling), it is necessary to redefine the nominal power of the resistor, taking into account the new load factor.

Determining the nominal power

Graph no. 1

Average power depending on the braking torque for a load factor

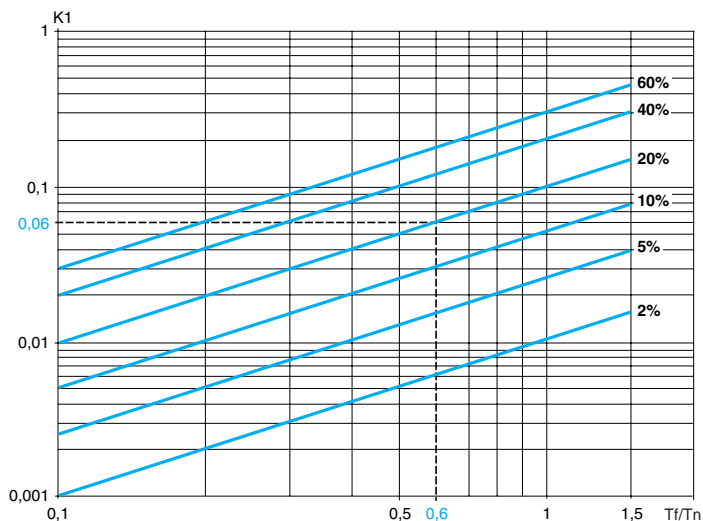

Example :
Motor power $P_m = 4$ kW
Motor efficiency $\eta = 0.85$
Braking torque $T_f = 0.6 T_n$
Braking time $t = 10$ s
Cycle time $T = 50$ s
Load factor $f_m = \frac{t}{T} = 20\%$

From graph no. 1 calculate the coefficient K_1 corresponding to a braking torque of $0.6 T_n$ and a load factor of 20%.
 $K_1 = 0.06$

Graph no. 2

Permissible resistor overload depending on time (typical curve)

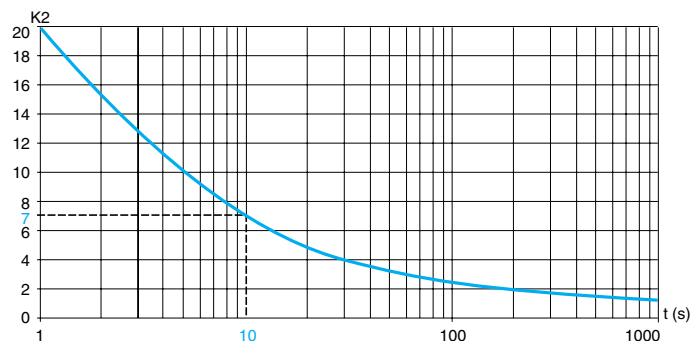

From graph no. 2 calculate the coefficient K_2 corresponding to a braking time of 10 seconds.
 $K_2 = 7$

Nominal power of the resistor (P_n) must be greater than :

$$P_n = P_m \times K_1 \times \eta \left(1 + \frac{1}{K_2 \times f_m} \right) = 4.10^3 \times 0.06 \times 0.85 \left(1 + \frac{1}{7 \times 0.2} \right) = 350 \text{ W}$$

Variable speed controllers for asynchronous motors

Altivar 58

Options : braking module and resistors

Characteristics :
pages 60141/2 and 60141/3
Dimensions :
page 60134/3

References

Braking module

For speed controllers	Reference	Weight kg
ATV-58●U09M2, ●U18M2	VW3-A58701	0.250

Unprotected braking resistors

For speed controllers	Ohmic value Ω	Average power available at 40 °C (1) W	Reference	Weight kg
ATV-58●U09M2, ●U18M2, ●U29M2, ATV-58●U18N4, ●U29N4, ●U41N4	100	32	VW3-A58702	0.600
ATV-58●U41M2, ●U54M2	68	32	VW3-A58704	0.600
ATV-58●U54N4, ●U72N4	100	40	VW3-A58703	0.850



VW3-A58702

(1) Power which can be dissipated by the resistor at a maximum temperature of 115 °C, corresponding to a maximum temperature limit of 75 °C in an ambient temperature of 40 °C.

Variable speed controllers for asynchronous motors

Altivar 58

Options : braking module and resistors

Characteristics :
pages 60141/2 and 60141/3
Dimensions :
page 60134/3

References

Protected braking resistors



VW3-A5873●

For speed controllers	Ohmic value	Average available power at 40 °C (1)	Reference	Weight
	Ω	W		kg
ATV-58●U09M2, ●U18M2, ●U29M2, ATV-58●U18N4, ●U29N4, ●U41N4	100	32	VW3-A58732	2.000
ATV-58●U41M2, ●U54M2	68	32	VW3-A58733	2.000
ATV-58●U54N4, ●U72N4	100	40	VW3-A58734	2.000
ATV-58●U90N4, ●D12N4	60	80	VW3-A58735	3.400
ATV-58●U72M2, ●D16N4, ●D23N4	28	200	VW3-A58736	5.100
ATV-58●U90M2, ●D12M2, ATV-58●D28N4, ●D33N4, ●D46N4, ATV-58HD28N4X, HD33N4X, HD46N4X	14	400	VW3-A58737	6.100
ATV-58HD16M2X, ●D54N4, HD54N4X ATV-58HD23M2X ATV-58HD28M2X, HD33M2X ATV-58●D64N4, ●D79N4 ATV-58HD64N4X, HD79N4X ATV-58HD46M2X	10 7.5 5 5 5 4.16	1000	VW3-A66704 (2)	17.000

(1) Power which can be dissipated by the resistor at a maximum temperature of 115 °C, corresponding to a maximum temperature limit of 75 °C in an ambient temperature of 40 °C.

(2) The different ohmic values are obtained depending on the connection and are detailed in the resistor manual.

Variable speed controllers for asynchronous motors

Altivar 58
Options : line chokes

Presentation, characteristics

Dimensions :
page 60134/5

Presentation

The line chokes provide improved protection against mains overvoltages and reduce the current harmonic distortion produced by the speed controller.

The chokes recommended are used to limit the line current.

The use of line chokes is especially recommended in the following cases :

- severe disturbance of mains supply by other receivers (interference, overvoltages),
- mains supply with voltage imbalance between phases > 1.8 % of the nominal voltage,
- speed controller supplied by a line with very low impedance (close to power transformers 10 times more powerful than the speed controller rating),
- installation of a large number of frequency inverters on the same line (reduction of line current),
- reduction of overload of the cos ϕ power factor correction capacitors, if the installation has a bank of power factor correction capacitors.

Line chokes must be used for supplying ATV-58●U72M2, ●U90M2 and ●D12M2 3-phase speed controllers via a single-phase 220 V supply.

Certain ATV-58 speed controllers are available with an integrated line choke which limits the line current to the nominal motor current value :

- ATV-58HD16M2X to HD46M2X, HD28N4 to HD79N4 and HD28N4X to HD79N4X speed controllers,
- ready-assembled ATV-58ED12N4 to ED79N4 speed controllers.

Characteristics

Conformity to standards	EN 50178 (VDE 0160 level 1 high-energy overvoltages on the mains supply)								
Voltage drop	Between 3 and 5 % inclusive of the supply nominal voltage. Higher values may cause a loss of torque.								
Type of choke	VZ1-L 004M010	VZ1-L 007UM50	VZ1-L 018UM20	VW3- A58501	VW3- A58502	VW3- A66501	VW3- A66502	VW3- A66503	VW3- A66504
Degree of protection									
Choke	IP 00	IP 00	IP 00	IP 00	IP 00	IP 00	IP 00	IP 00	IP 00
Terminals	IP 20	IP 20	IP 20	IP 10	IP 10	IP 20	IP 20	IP 20	IP 10
Value of inductance (mH)	10	5	2	2	1	10	4	2	1
Nominal current (A)	4	7	18	25	45	4	10	16	30
Losses (W)	17	20	30	45	50	45	65	75	90

Variable speed controllers for asynchronous motors

Altivar 58
Options : line chokes

References

Dimensions :
page 60134/5



VW3-A6650●

References

Altivar 58		Line current				Choke	Weight
Prospective line I _{sc}	Single phase or 3-phase	without choke at		with choke at		Reference	
kA		U min	at U max	U min	at U max		kg
		A	A	A	A		
Single phase supply voltage : 200...240 V (1) 50/60 Hz							
2	ATV-58●U09M2	5.6	4.7	3.7	3.1	VZ1-L004M010	0.630
2	ATV-58●U18M2	9.8	8.3	7.1	5.7	VZ1-L007UM50	0.880
5	ATV-58●U29M2	18.5	15.6	13.2	12	VZ1-L018UM20	1.990
5	ATV-58●U41M2	24.8	21.1	18.6	16	VZ1-L018UM20	1.990
5	ATV-58●U72M2	(2)	(2)	24.7	21.3	VW3-A58501	3.500
22	ATV-58●U90M2	(2)	(2)	35	30	VW3-A58502	3.500
22	ATV-58●D12M2	(2)	(2)	46	39.4	VW3-A58502	3.500
3-phase supply voltage : 200...240 V (1) 50/60 Hz							
5	ATV-58●U29M2	9.7	8.3	6.3	5.3	VW3-A66502	3.000
5	ATV-58●U41M2	13.4	11.4	5.5	5.1	VW3-A66503	3.500
5	ATV-58●U54M2	17.2	15	12	10	VW3-A66503	3.500
5	ATV-58●U72M2	24.4	19.5	16	13.5	VW3-A66504	6.000
22	ATV-58●U90M2	34.7	30	22	18.5	VW3-A66504	6.000
22	ATV-58●D12M2	44.4	38.2	29.5	24.3	VW3-A66504	6.000
3-phase supply voltage : 380...500 V (1) 50/60 Hz							
5	ATV-58●U18N4	3.4	2.6	1.8	1.5	VW3-A66501	1.500
5	ATV-58●U29N4	6	4.5	3.3	2.5	VW3-A66501	1.500
5	ATV-58●U41N4	7.8	6	4.8	3.8	VW3-A66502	3.000
5	ATV-58●U54N4	10.2	7.8	6.4	5	VW3-A66502	3.000
5	ATV-58●U72N4	13	10.1	8.3	6.4	VW3-A66502	3.000
5	ATV-58●U90N4	17	13.2	11.6	9.3	VW3-A66503	3.500
22	ATV-58●D12N4	26.5	21	15.4	11.9	VW3-A66503	3.500
22	ATV-58●D16N4	35.4	28	22.7	17.9	VW3-A66504	6.000
22	ATV-58●D23N4	44.7	35.6	29.4	22.7	VW3-A66504	6.000

(1) Nominal supply voltage : U min...U max

(2) Compulsory line choke

Variable speed controllers for asynchronous motors

Altivar 58

Options : additional radio interference suppression input filters

Dimensions :
page 60134/5
Schemes :
page 60135/8

Presentation, characteristics

Presentation

Function

The Altivar 58 incorporates radio interference suppression input filters to comply with the EMC "products" standards IEC 1800-3 and EN 61800-3 concerning variable speed controllers. Compliance with these standards meets the requirements of the European directive on EMC.

Certain ATV-58 speed controllers are available without input filters, in situations where EMC conformity is not necessary :

- ATV-58HD28N4 to HD79N4 speed controllers are available with or without integrated input filters (in this case, the speed controller reference ends with **X**),
- ATV-58HD16M2X to HD46M2X speed controllers are not available with integrated input filters.

Certain ATV-58 speed controllers cannot be ordered without integrated input filters :

- ATV-58●U09M2 to ●D12M2 speed controllers,
- ATV-58●U18N4 to ●D23N4 speed controllers.

The additional filters meet the strictest requirements : these filters are designed to reduce conducted emissions on the mains supply to below the limits of standards EN 55011 class A (1) or EN 55022 class B.

The filters are mounted under the ATV-58H speed controllers (with heatsinks). They have tapped holes for fixing to the speed controllers which they support. In the case of ATV-58P speed controllers (on baseplate), and of ATV-58E (ready-assembled) the filters are fixed to the side of the speed controller.

(1) If the cable is longer than 5 m for ATV-58●U09M2 to ●D12M2 and ●U18N4 to ●D23N4 speed controllers.
If the cable is longer than 25 m for ATV-58HD28N4 to HD79N4 speed controllers.

Use according to the type of mains supply

These filters can only be used on TN type (connected to neutral) and TT type (neutral to earth) mains supplies.

These filters must not be used with IT (impeding or isolated neutral) mains supplies.

Standard IEC 1800-3, appendix D2.1, states that, for this type of supply, filters must not be used as they prevent the earth leakage detectors from working reliably.

In addition, the effectiveness of the filters on this type of supply depends on the type of impedance between neutral and earth and is therefore not recommended.

In the case of a machine which must be installed on an IT supply, the solution is to insert an isolation transformer and operate the machine locally using a TN or TT supply.

Characteristics

Conformity to standards			EN 133200
Degree of protection			IP 21 and IP 41 on upper part
Maximum relative humidity			93 % with no condensation or dripping water conforming to IEC 68-2-3
Ambient air temperature around the device	Operation	°C	-10... + 60
	Storage	°C	- 25...+ 70
Maximum operating altitude	Without derating	m	1000 (above this derate the current by 1% for each additional 100m)
Maximum nominal voltage	50/60 Hz single phase	V	240 + 10 %
	50/60 Hz 3-phase	V	500 + 10 %

Variable speed controllers for asynchronous motors

Altivar 58

Options : additional radio interference suppression input filters

Dimensions :
page 60134/5
Schemes :
page 60135/8

References

For speed controllers Reference	Filter Maximum length of shielded cable		In	Reference	Weight
	EN 55011 class A (1)	EN 55022 class B (1)	(2)		
	m	m	A		kg
Single phase supply voltage : 200...240 V - 50/60 Hz					
ATV-58●U09M2, ●U18M2	50	20	10	VW3-A58401	1.700
ATV-58●U29M2, ●U41M2	50	20	25	VW3-A58402	3.600
ATV-58●U72M2	50	20	25	VW3-A58403	5.000
ATV-58●U90M2, ●D12M2	50	20	45	VW3-A58404	10.000
3-phase supply voltage : 200...240 V - 50/60 Hz					
ATV-58●U29M2, ●U41M2	50	20	25	VW3-A58402	3.600
ATV-58●U54M2, ●U72M2	50	20	25	VW3-A58403	5.000
ATV-58●U90M2, ●D12M2	50	20	45	VW3-A58404	10.000
3-phase supply voltage : 208...240 V - 50/60 Hz					
ATV-58HD16M2X, HD23M2X	(3)	(3)	80	VW3-A58407	13.000
ATV-58HD28M2X, HD33M2X ATV-58HD46M2X	(3)	(3)	160	VW3-A58408	20.000
3-phase supply voltage : 380...500 V - 50/60 Hz					
ATV-58●U18N4, ●U29N4, ATV-58●U41N4	50	20	25	VW3-A58402	3.600
ATV-58●U54N4, ●U72N4, ATV-58●U90N4	50	20	25	VW3-A58403	5.000
ATV-58●D12N4, ●D16N4	50	20	45	VW3-A58404	10.000
ATV-58●D23N4	50	20	45	VW3-A58405	13.000
ATV-58HD28N4 ATV-58HD28N4X	200 (3)	100 (3)	50 50	VW3-A58406	13.000
ATV-58HD33N4, HD46N4 ATV-58HD33N4X, HD46N4X	200 (3)	100 (3)	80 80	VW3-A58407	13.000
ATV-58HD54N4, HD64N4, HD79N4, ATV-58HD54N4X, HD64N4X, HD79N4X	200 (3)	100 (3)	160 160	VW3-A58408	20.000

(1) The filter selection tables give the maximum length for the shielded cables which connect the motors to the speed controllers, for a switching frequency of 0.5 to 12 kHz. These limits are given for information only as they depend on the interference capacity of the motors and the cables used. For motors connected in parallel, the total of the lengths must be taken into account.

(2) In : Nominal current of the filter.

(3) Value not available.

Variable speed controllers for asynchronous motors

Altivar 58

Options : output filters and motor line chokes

Presentation, principle

Dimensions :
page 60134/5

Presentation

An output filter inserted between the speed controller and the motor provides :

- Limitation of $\frac{dv}{dt}$ at motor terminals (500 to 1500 V/ μ s), for cables over 50 m long
- Filtering of interference caused by the opening of a contactor placed between the filter and the motor
- Reduction of the motor earth leakage current

Our range offers three types of filter.

Principle

LR filter cell : this cell comprises 3 high frequency line chokes and 3 resistors.

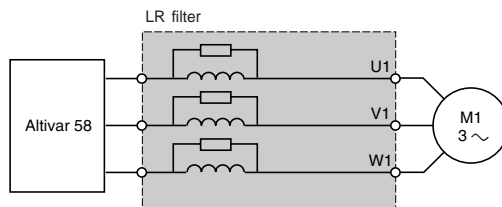

LC filter cell : this cell comprises 3 high frequency line chokes and 3 capacitors.

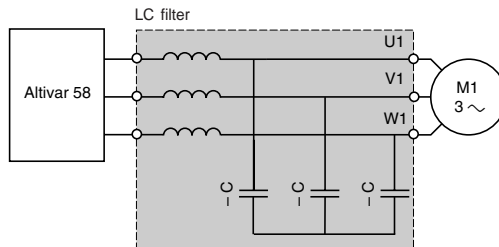

Line choke + capacitor combination : this assembly comprises 3 capacitors in delta connection mounted in a box connected to a 3-phase line choke VW3-A6650.

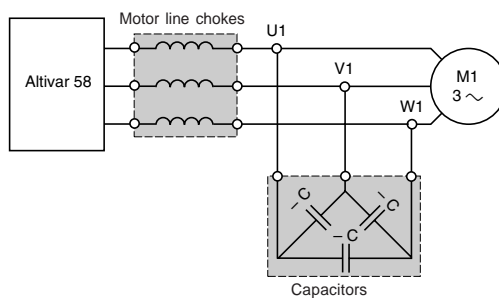

Motor line chokes

For standard motor cable lengths over 100 m (50 m for shielded cables), a line choke limits overvoltages at the motor terminals.

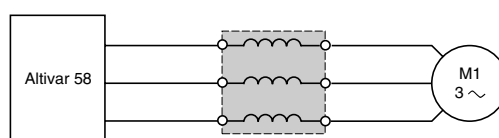

Variable speed controllers for asynchronous motors

Altivar 58

Options : output filters and motor line chokes

Characteristics, references

Dimensions :
page 60134/5

Characteristics (1)

LR filter cells

Speed controller switching frequency	kHz	0.5...4 max (2)
Length l of motor cable	m	≤ 100 (shielded wires)
Degree of protection		IP 20

LC filter cells

Types of LC filter		Line chokes : VW3-A66650 + capacitors VW3-A66421		LC filter cell : VW3-A6641	
Speed controller switching frequency	kHz	2 or 4	12	2 or 4	12
Length l of motor cable	Shielded wires	m	≤ 40	≤ 20	≤ 50
	Unshielded wires	m	≤ 80	≤ 40	≤ 100

References

LR filter cells

For speed controllers	Losses	Nominal current	Reference	Weight kg
ATV-58●U18M2, ●U29M2, ATV-58●U18N4, ●U29N4, ●U41N4, ●U54N4, ATV-58●U72N4	150 W	10 A	VW3-A58451	7.400
ATV-58●U41M2, ●U54M2, ●U72M2, ●U90M2, ATV-58●U90N4, ●D12N4, ●D16N4	180 W	25 A	VW3-A58452	7.400
ATV-58●D12M2, ●D23N4	220 W	45 A	VW3-A58453	12.500

Line choke (3) + capacitor combinations

For speed controllers	Description	Reference	Weight kg
ATV-58HD16M2X	Motor line chokes Capacitors (4)	VW3-A66505 VW3-A66421	11.000 0.250
ATV-58HD23M2X, HD28M2X, HD33M2X, ATV-58●D28N4, ●D33N4, ●D46N4, ATV-58HD28N4X, HD33N4X, HD46N4X	Motor line chokes Capacitors (4)	VW3-A66506 VW3-A66421	16.000 0.250
ATV-58HD46M2X, ●D54N4, ●D64N4, ●D79N4, ATV-58HD54N4X, HD64N4X, HD79N4X	Motor line chokes Capacitors (4)	VW3-A66507 VW3-A66421	45.000 0.250

LC filter cell in high torque applications

ATV-58●D28N4, ●D33N4, ●D46N4, ATV-58HD28N4X, HD33N4X, HD46N4X, ATV-58HD16M2X, HD23M2X	LC filter cell	VW3-A66412	35.000
ATV-58●D54N4, ●D64N4, ●D79N4, ATV-58HD54N4X, HD64N4X, HD79N4X, ATV-58HD28M2X, HD33M2X	LC filter cell	VW3-A66413	40.000

LC filter cell in standard torque applications

ATV-58●D28N4, ●D33N4, HD28N4X, HD33N4X	LC filter cell	VW3-A66412	35.000
ATV-58●D46N4, ●D54N4, ●D64N4, ATV-58HD46N4X, HD54N4X, HD64N4X, ATV-58HD16M2X, HD23M2X	LC filter cell	VW3-A66413	40.000

Motor line chokes (5)

ATV-58HD16M2X	Motor line choke	VW3-A66505	11.000
ATV-58HD23M2X, HD28M2X, HD33M2X, ATV-58●D23N4, ●D28N4, ●D33N4, ●D46N4 ATV-58HD28N4X, HD33N4X, HD46N4X	Motor line choke	VW3-A66506	16.000
ATV-58HD46M2X, ●D54N4, ●D64N4, ●D79N4 ATV-58HD54N4X, HD64N4X, HD79N4X	Motor line choke	VW3-A66507	45.000

(1) To ensure the filters perform at optimum level, observe the cable length between the motor and the speed controller given in the table above. For an application using several motors connected in parallel, the cable length must be the total length including all tap-offs. There is a risk of the filters overheating if a cable longer than the recommended length is used.

(2) For frequencies above 4 kHz or cables longer than 100 metres, consult your Regional Sales Office.

(3) It is not advisable to connect option VW3-A66421 to the speed controller terminals without line chokes, as this could cause the speed controller to fail.

(4) Connection to the S1, S2, S3 terminals of the selected line choke using wires of 1.5 mm² cross-section.

(5) Degree of protection IP 20.

Variable speed controllers for asynchronous motors

Presentation :
pages 60131/2 to 60131/6
Characteristics :
pages 60131/7 to 60131/9
References :
pages 60132/2 to 60132/4
Functions :
pages 60133/2 to 60133/25

Altivar 58

Dimensions

ATV-58H●●●● (with heatsink)

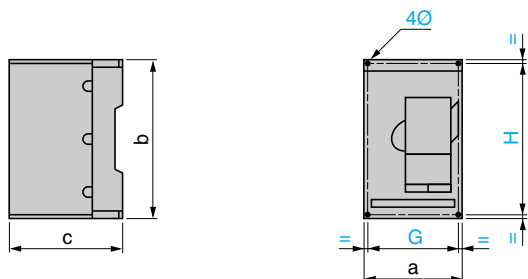

ATV-58H	a	b	c	G	H	Ø
U09M2, U18M2	113	206	167	96	190	5
U29M2, U41M2, U18N4, U29N4, U41N4	150	230	184	133	210	5
U54M2, U72M2, U54N4, U72N4, U90N4	175	286	184	155	270	5.5
U90M2, D12M2, D12N4, D16N4	230	325	210	200	310	5.5
D23N4	230	415	210	200	400	5.5
D16M2X, D23M2X, D28N4, D33N4, D46N4	240	550	283	205	530	7
D28N4X, D33N4X, D46N4X	240	550	283	205	530	7
D28M2X, D33M2X, D46M2X, D54N4, D64N4, D79N4	350	650	304	300	619	9
D54N4X, D64N4X, D79N4X	350	650	304	300	619	9

ATV-58P●●●● (on baseplate)

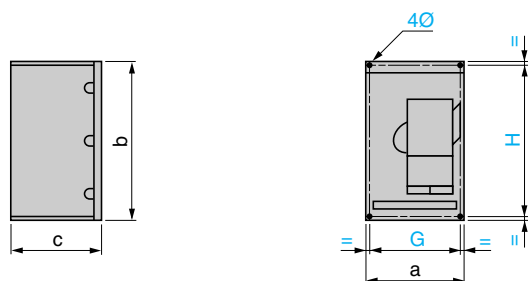

ATV-58P	a	b	c	G	H	Ø
U09M2, U18M2	113	206	132	96	190	5
U29M2, U41M2, U18N4, U29N4, U41N4	150	230	145	133	210	5
U54M2, U72M2, U54N4, U72N4, U90N4	175	286	151	155	270	5.5
U90M2, D12M2, D12N4, D16N4	230	325	159	200	310	5.5
D23N4	230	415	159	200	400	5.5

Variable speed controllers for asynchronous motors

Altivar 58

Presentation :
page 60141/2
Characteristics :
pages 60141/2 and 60141/3
References :
pages 60141/4 and 60141/5

Dimensions (continued)

Protected braking resistors VW3-A58732 to A58734

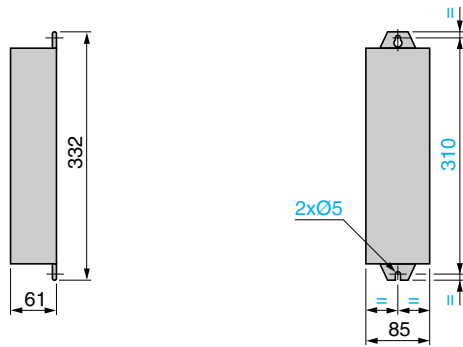

VW3-A58735 to A58737

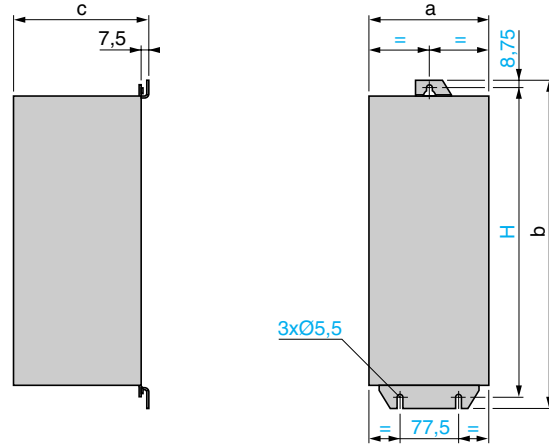

VW3-	a	b	c	H
A58735	163	340	61	320
A58736, A58737	156	434	167	415

VW3-A66704

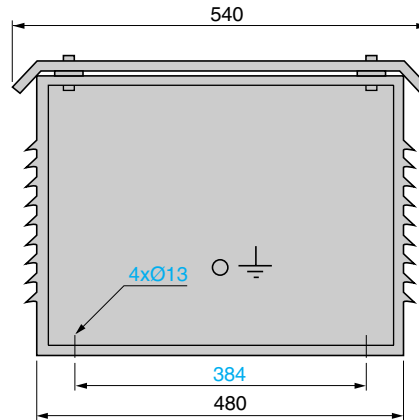
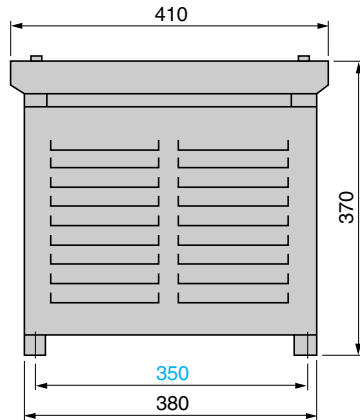

Unprotected braking resistors VW3-A58703

2-wire output, length 0.5 m

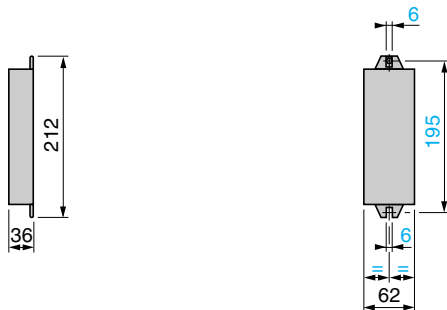

VW3-A58702 and A58704

2-wire output, length 0.5 m

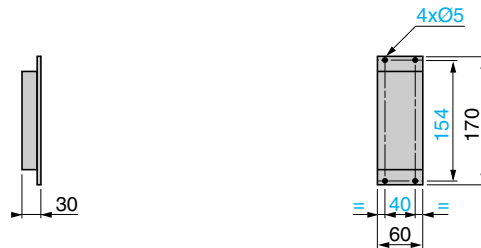

Braking module VW3-A58701

(mounted on AM1-ED mounting rail)



Variable speed controllers for asynchronous motors

Altivar 58

Dimensions (continued)

Presentation :
pages 60132/5 to 60132/7
References :
pages 60132/5 to 60132/7

Kit for mounting in dust and damp proof enclosure VW3-A58802 to A58805

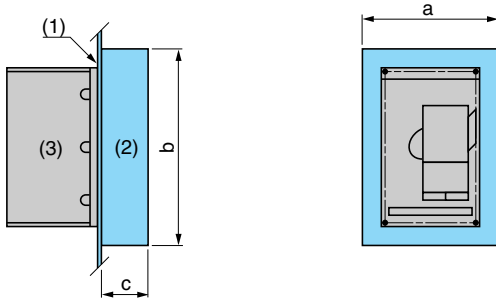

VW3-	a	b	c
A58802	150	226	80
A58803	175	450	80
A58804	225	370	62
A58805	225	460	62

(1) Metal plate of enclosure
(2) VW3-A58802 to VW3-A58805
(3) Speed controller

Kit for mounting air exchanger VW3-A58806 and A58807

Example of connecting upper bellows on a side panel

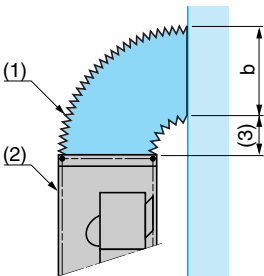

VW3-	b
A58806	240
A58807	350

(1) VW3-A58806 and VW3-A58807
(2) Speed controller
(3) 100 mm minimum

Control card fan kit VW3-A58821 to A58826

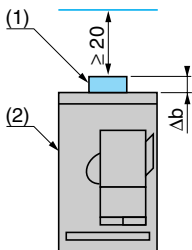

VW3-	Δb
A58821	16
A58822	25
A58823	25
A58824	25
A58825	60
A58826	60

(1) VW3-A58821 to VW3-A58824
(2) Speed controller

Kit for removable power terminals VW3-A58811 to A58813

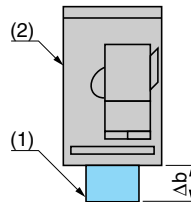

VW3-	Δb
A58811	52
A58812	54
A58813	54

(1) VW3-A58811 to VW3-A58813
(2) Speed controller

Variable speed controllers for asynchronous motors

Altivar 58

Presentation :
pages 60142/2 to 60144/3
Characteristics :
pages 60142/2 to 60144/3
References :
pages 60142/3 to 60144/3

Dimensions (continued)

3-phase chokes VW3-A66501 to A66507

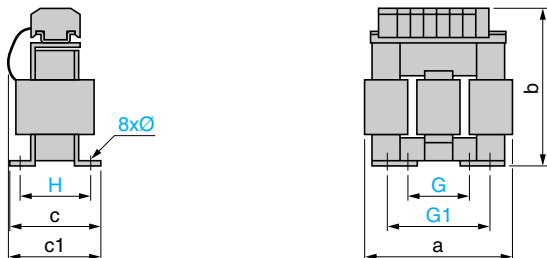

VW3-	a	b	c	c1	G	G1	H	Ø
A66501	100	135	55	60	40	60	42	6 x 9
A66502	130	155	85	90	60	80.5	62	6 x 12
A66503	130	155	85	90	60	80.5	62	6 x 12
A66504	155	170	115	135	75	107	90	6 x 12
A66505	180	210	125	165	85	122	105	6 x 12
A66506	275	210	130	160	105	181	100	11 x 22
A66507	320	290	172	215	190	230	142	-

Radio interference suppression filters (EMC) VW3-A58401 to A58407

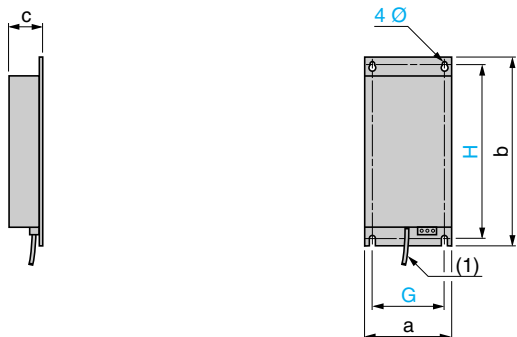

VW3-	a	b	c	G	H	Ø
A58401	113	246	36	94.5	230	5
A58402	150	276	50	133	260	5
A58403	175	340	60	153	320	6
A58404	230	390	60	200	370	6
A58405	230	480	60	200	460	6
A58406, A58407	240	690	85	205	650	7
A58408	350	770	90	300	770	9

(1) Cable.

Plate for EMC mounting (supplied with the speed controller)

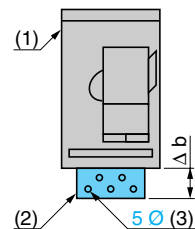

Mounting on ATV-58●	Δb	Ø (3)
U09M2, U18M2	63	M4
U29M2, U41M2, U18N4, U29N4, U41N4	64.5	M4
U54M2, U72M2, U54N4, U72N4, U90N4	64.5	M4
U90M2, D12M2, D12N4, D16N4	62	M4
D23N4	62	M4
D16M2X, D23M2X, D28N4, D33N4, D46N4	80	M5
D28M2X, D33M2X, D46M2X, D54N4, D64N4, D79N4	110	M5

(1) Speed controller.

(2) Plate.

(3) Tapped holes for fixing EMC clamps.

Single phase chokes VZ1-L●●●●●●, VW3-A58501 and VW3-A58502



	a	b	c	G	H	Ø
VZ1-L004M010	60	100	80	50	44	4 x 9
VZ1-L007UM50	60	100	95	50	60	4 x 9
VZ1-L018UM20	85	120	105	70	70	5 x 11
VW3-A58501	128	150	95	70	65	5 x 11
VW3-A58502	128	150	105	70	77	6 x 12

Output filters VW3-A58451 to A58453

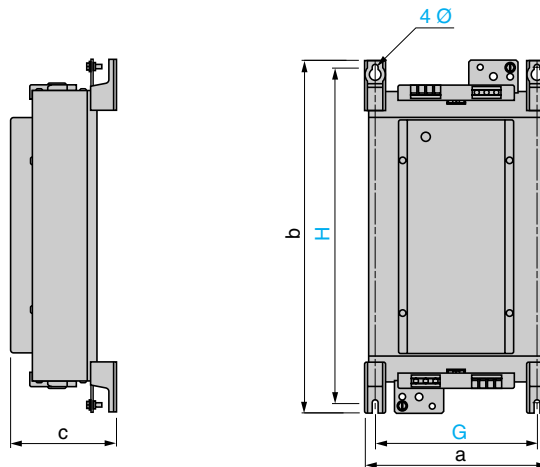

VW3-	a	b	c	G	H	Ø
A58451, A58452	169.5	420	123	150	315	7
A58453	239	467.5	139.5	212	444	7

Variable speed controllers for asynchronous motors

Presentation :
pages 60131/2 to 60131/6
Characteristics :
pages 60131/7 to 60131/9
Dimensions, schemes :
pages 60134/2 to 60135/8
Functions :
pages 60133/2 to 60133/25

Altivar 58 Mounting options

Selection

Depending on the conditions in which the speed controller is to be used, setup will require certain installation precautions as well as the appropriate accessories.

Install the unit vertically at $\pm 10^\circ$.

- Do not place it close to heating elements
- Leave sufficient free space to ensure that the air required for cooling purposes can circulate from the bottom to the top of the unit.

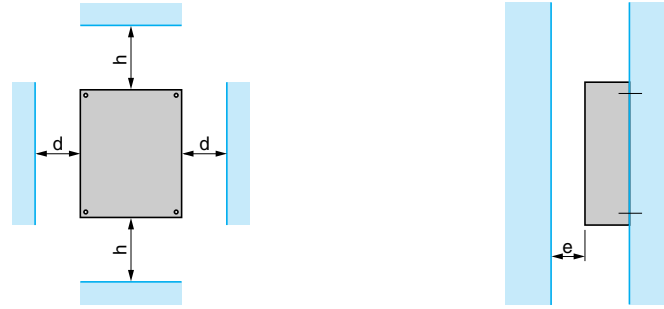

Mounting recommendations

Speed controller with heatsink

ATV-58 speed controllers	Temperature		
HU09M2 to HU72M2 and HU18N4 to HU90N4 e = 10 mm h = 50 mm	- 10...+ 40 °C d ≥ 50 mm No special precautions d = 0 mm Remove the protective blanking cover from the top of the speed controller (degree of protection is then IP 20)	+ 40...+ 50 °C d ≥ 50 mm Remove the protective blanking cover from the top of the speed controller (degree of protection is then IP 20) d = 0 mm Add control card fan kit VW3-A5882● (see previous pages)	+ 50...+ 60 °C d ≥ 50 mm Add control card fan kit VW3-A5882● (see previous pages) Derate the rated operating current by 2.2 % for each °C over 50 °C
HU90M2 to HD12M2 and HD12N4 to HD23N4 e = 10 mm h = 50 mm	- 10...+ 40 °C d ≥ 50 mm No special precautions d = 0 mm Remove the protective blanking cover from the top of the speed controller (degree of protection is then IP 20)	+ 40...+ 50 °C d ≥ 50 mm Remove the protective blanking cover from the top of the speed controller (degree of protection is then IP 20) Derate the rated operating current by 2.2 % for each °C over 40 °C d = 0 mm Add control card fan kit VW3-A5882● (see previous pages) Derate the rated operating current by 2.2 % for each °C over 40 °C	-
HD16M2X to HD46M2X, HD28N4 to HD79N4 and HD28N4X to HD79N4X e = 50 mm h = 100 mm	- 10...+ 40 °C d ≥ 50 mm No special precautions	+ 40...+ 60 °C d ≥ 50 mm Add control fan card kit VW3-A5882● (see previous pages) Derate the rated operating current by 2.2 % for each °C over 40 °C	

Variable speed controllers for asynchronous motors

Presentation :
pages 60131/2 to 60131/6
Characteristics:
pages 60131/7 to 60131/9
Dimensions, schemes :
pages 60134/2 to 60135/8
Functions :
pages 60133/2 to 60133/25

Altivar 58
Mounting options

Selection (continued)

Mounting precautions (continued)

Speed controller on a baseplate (use the VW3-A5880● kit, see the following pages)

● Mounting in a wall-fixing or floor standing enclosure

- External ambient temperature (heatsink side VW3-A5880●) : - 10...+ 40 °C.

- Temperature inside the wall-fixing or floor-standing enclosure : this has the same limits, mounting conditions and derating (if any) as for speed controllers with heatsinks, see opposite.

● Mounting on machine frame

Ambient temperature : - 10...+ 40 °C.

Mounting precautions for a wall-fixing or floor standing enclosure

Risk of condensation

If the device is left switched off for long periods, a heater must be used (0.2 to 0.5 W per 10 cm³ of the enclosure) which switches on automatically as soon as the device stops.

This keeps the interior of the enclosure at a temperature slightly above the external temperature, and avoids any risk of condensation or dripping water while the device is switched off.

Alternative solution : Keep the device powered up when it is stopped (the heat of the device itself when powered up is generally sufficient to cause this temperature difference).

Dust and damp proof casing

Calculating the size of the enclosure

Usable heat dissipation area of casing (if wall-mounted) : $S = \frac{K}{R_{th}}$

Where :

S (m²) = area of sides + area of top + area of front panel

K : thermal resistance per m² of casing

For metal casing : $K = 0.12$ with internal fan, $K = 0.15$ without fan.

R_{th} : maximum thermal resistance in °C/W :

$R_{th} = \frac{\theta - \theta_e}{P}$ where : θ = maximum temperature inside enclosure in °C,
 θ_e = maximum external temperature in °C,
 P = total power dissipated in the enclosure in W.

The total power dissipated in the enclosure consists of : the power dissipated by the speed controller (see reference tables) plus the power dissipated by the other components of the unit.

Attention : Do not use insulated enclosures as they have a poor level of conductivity.

Using the speed controller on a baseplate reduces the power dissipated in the enclosure, which makes the IP 54 degree of protection easier to achieve.

To avoid hot spots, add the control card fan kit to circulate the air inside the speed controller.

Variable speed controllers for asynchronous motors

Presentation :
pages 60131/2 to 60131/6
Characteristics :
pages 60131/7 to 60131/9
Dimensions, schemes :
pages 60134/2 to 60135/8
Functions :
pages 60133/2 to 60133/25

Altivar 58
Mounting options

Selection (continued)

Recommendations for mounting in a wall-fixing or floor-standing enclosure (continued)

Ventilated casing

The apertures and/or optional fans must permit a flow rate at least equal to that provided by the speed controller fans.

Fan flow rate according to speed controller rating

Type of speed controller		Fan flow rate
With heatsink	ATV-58HU09M2, HU18M2, ATV-58HU18N4	Non-ventilated
	ATV-58HU29M2, HU54M2, ATV-58HU29N4, HU41N4, HU54N4	36 m ³ /hr
	ATV-58HU41M2	47 m ³ /hr
	ATV-58HU72M2, HU90M2, HD12M2, ATV-58HU72N4, HU90N4, HD12N4, HD16N4, HD23N4	72 m ³ /hr
	ATV-58HD16M2X, HD23M2X, ATV-58HD28N4 to HD46N4, ATV-58HD28N4X to HD46N4X (1)	292 m ³ /hr
	ATV-58HD28M2X to HD46M2X, ATV-58HD54N4 to HD79N4, ATV-58HD54N4X to HD79N4X (1)	492 m ³ /hr
	Control card fan kit	36 m ³ /hr
On baseplate	All ratings except ATV-58PU41M2	Non-ventilated
	ATV-58PU41M2	11 m ³ /hr
	Control card fan kit	36 m ³ /hr

(1) For these speed controllers use the air exchanger mounting kit : see page 60132/5.

Variable speed controllers for asynchronous motors

Presentation :
 pages 60131/2 to 60131/6
 Characteristics :
 pages 60131/7 to 60131/9
 Dimensions, schemes :
 pages 60134/2 to 60135/8
 Functions :
 pages 60133/2 to 60133/25

Altivar 58
 Mounting options

Selection (continued)

Recommendations for mounting on machine frame (speed controllers on baseplate)

Speed controllers on baseplates with the following ratings can be mounted on (or in) a cast iron or aluminium machine frame as long as the following conditions are observed :

- maximum ambient temperature : 40 °C
- mating surface (A) on frame machined to provide 100 µm max smoothness and 3.2 µm max roughness
- the speed controller must be mounted in the centre of a support (frame) with minimum thickness (e) and minimum square area of cooling surface (s) exposed to the open air.

This usage should be checked first by a test when the operating conditions are close to the maximum limits (power, cycle and temperature).

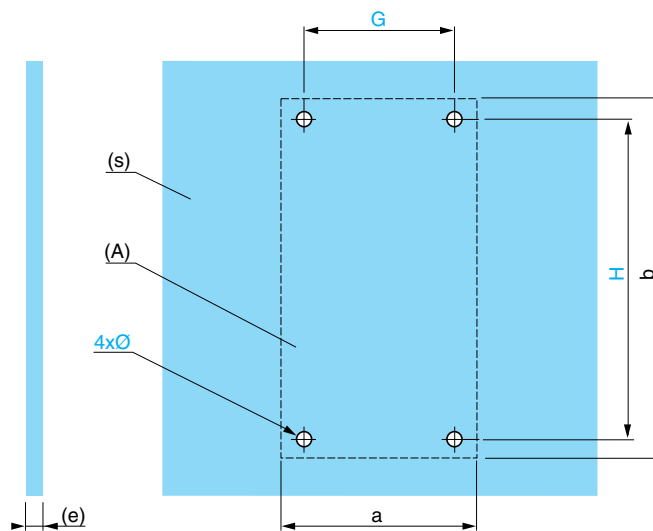

- (s) Minimal surface of support
 (A) Minimum machined surface
 (e) Thickness of support

Speed controllers	Minimum surface (s) m ²	Minimum thickness (e) mm ²		a	b	G	H	Ø
		Cast iron	Aluminium					
ATV-58PU09M2, PU18M2	0.25	20	10	120	220	96	189	M4
ATV-58PU29M2, PU41M2, ATV-58PU18N4, PU29N4, PU41N4	1	–	20	160	240	133	209	M5

Variable speed controllers for asynchronous motors

Altivar 58

Schemes, compatibility

Presentation :
pages 60131/2 to 60131/6
Characteristics :
pages 60131/7 to 60131/9
References :
pages 60132/2 to 60132/4
Functions :
pages 60133/2 to 60133/25

Schemes without contactor, recommended for machines which are not dangerous

3-phase supply

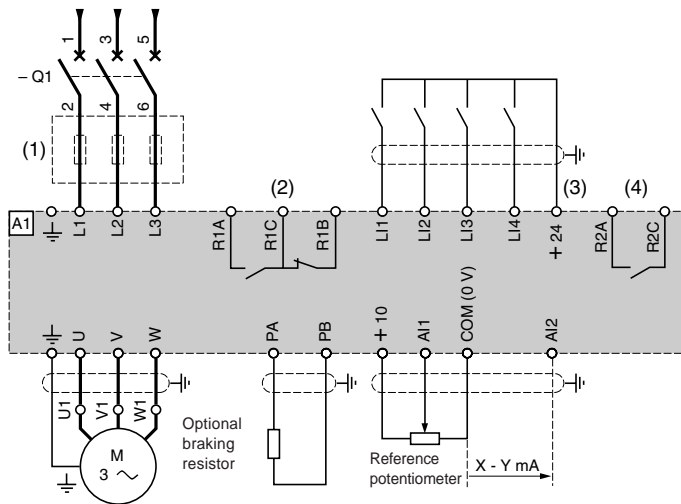

Single phase supply

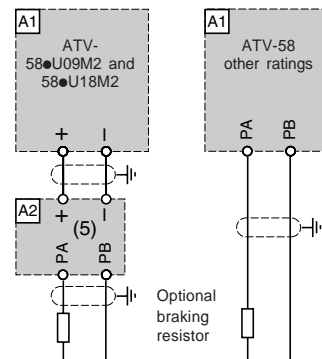
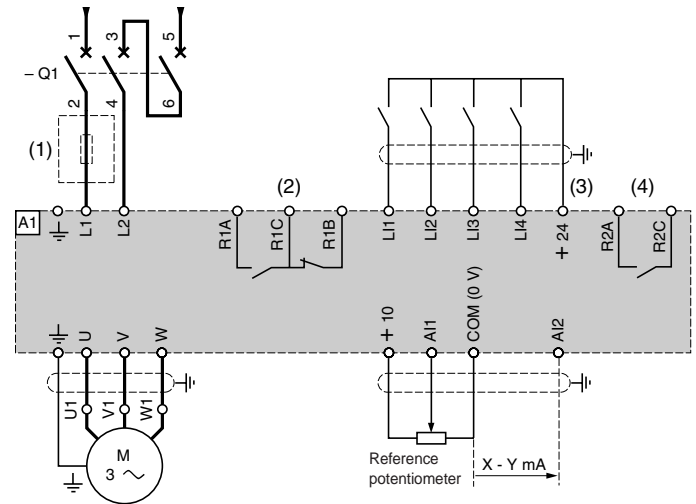

(1) Optional line choke

(2) Fault relay contacts; for remote signalling of speed controller status.

(3) Internal + 24 V. If an external + 24 V supply is used, connect the 0 V on the external supply to the COM terminal, do not use the + 24 terminal of the speed controller, and connect the common of the LI inputs to the + 24 V of the external supply.

(4) R2 relay can be reassigned.

(5) VV3-A58701 braking module, if a braking resistor is used, for ratings ATV-58 U09M2 and U18M2 only.

Note :
- All the terminals are located at the bottom of the controller.
- Fit suppressors to all the specific circuits close to the controller or connected on the same circuit, such as relays, contactors, solenoid valves, fluorescent lighting, etc.

Compatible components (for complete references, consult our specialist catalogue)

Code	Description
Q1	GV2-L or Compact NS (see following pages)

Variable speed controllers for asynchronous motors

Presentation :
pages 60131/2 to 60131/6
Characteristics :
pages 60131/7 to 60131/9
References :
pages 60132/2 to 60132/4
Functions :
pages 60133/2 to 60133/25

Altivar 58

Schemes, compatibility (continued)

Schemes with line contactor, recommended for dangerous machines which are switched on or off infrequently

3-phase supply

Single phase supply

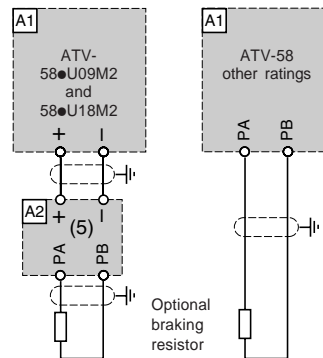
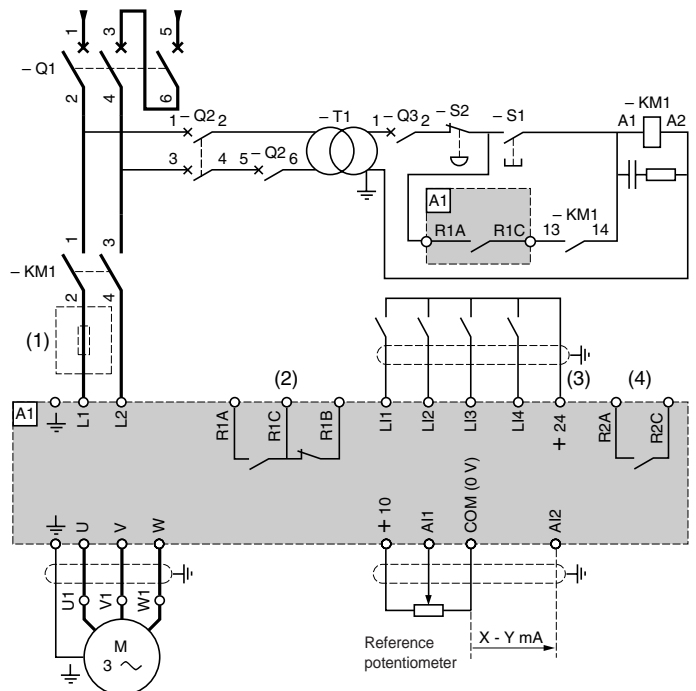
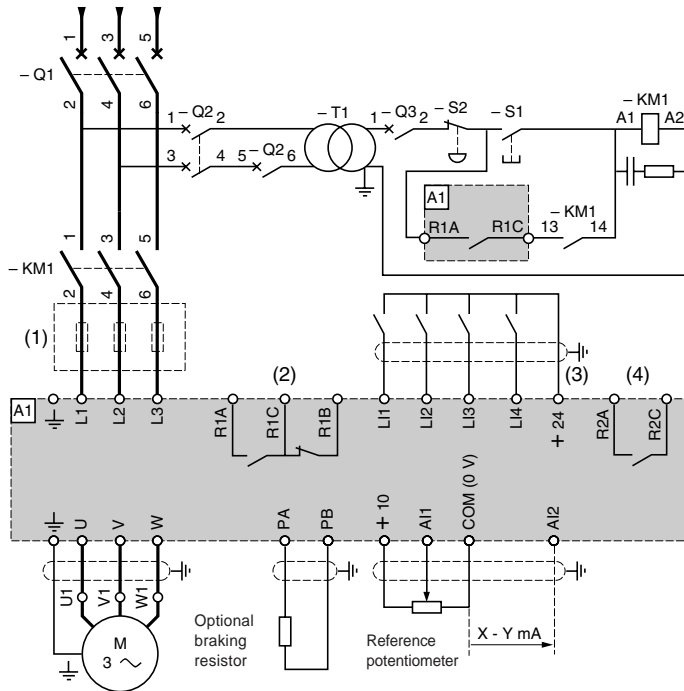

- (1) Optional line choke
- (2) Fault relay contacts; for remote signalling of speed controller status.
- (3) Internal + 24 V. If an external + 24 V supply is used, connect the 0 V on the external supply to the COM terminal, do not use the + 24 of the speed controller, and connect the common of the LI inputs to the + 24 V of the external supply.
- (4) R2 relay can be reassigned.
- (5) VW3-A58701 braking module, if a braking resistor is used, for ratings ATV-58●U09M2 and ●U18M2 only.

Note :

- All the terminals are located at the bottom of the controller.
- Fit suppressors to all the specific circuits close to the controller or connected on the same circuit, such as relays, contactors, solenoid valves, fluorescent lighting, etc.

Compatible components (for complete references, consult our specialist catalogue)

Code	Description
Q1	GV2-L or Compact NS (see following pages)
KM1	LC1-D●● + LA4-DA2U (see following pages)
S1, S2	XB2-B or XA2-B pushbuttons
T1	100 VA transformer 220 V secondary
Q2	GV2-L rated at twice the nominal primary current of T1
Q3	GB2-CB05

Variable speed controllers for asynchronous motors

Presentation :
pages 60131/2 to 60131/6
Characteristics :
pages 60131/7 to 60131/9
References :
pages 60132/2 to 60132/4
Functions :
pages 60133/2 to 60133/25

Altivar 58

Schemes, compatibility (continued)

Speed controllers ATV-58●U09M2 to ●D12M2 and ●U18N4 to ●D23N4

Schemes with downstream contactor, recommended for dangerous machines which are switched on and off frequently

3-phase supply

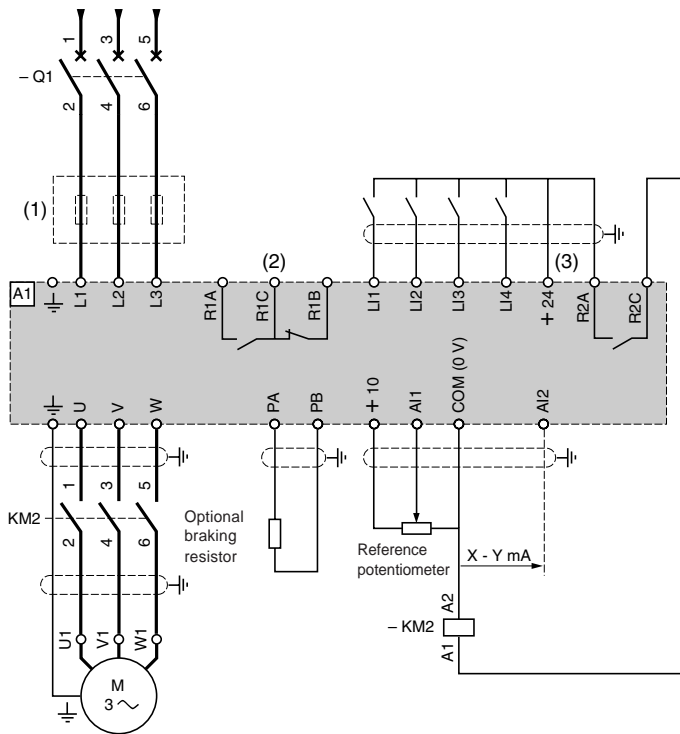

Single phase supply

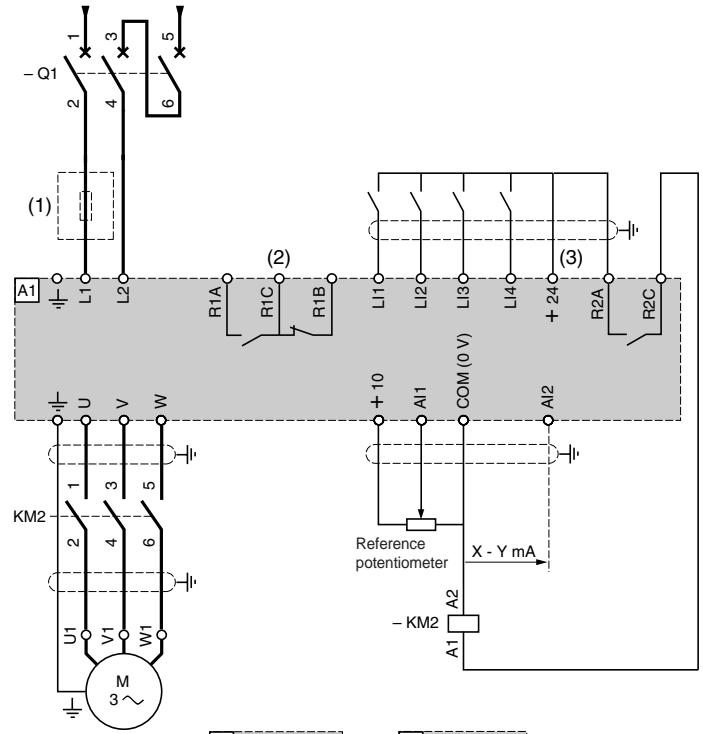

- (1) Optional line choke
(2) Fault relay contacts; for remote signalling of speed controller status.
(3) Internal + 24 V. If an external + 24 V supply is used, connect the 0 V on the external supply to the COM terminal, do not use the + 24 V of the speed controller, and connect the common of the LI inputs to the + 24 V of the external supply.
(4) VW3-A58701 braking module, if a braking resistor is used, for ratings ATV-58●U09M2 and ●U18M2 only.
(5) Use the "downstream contactor control" function with relay R2 (or the logic output LO of one of the "I/O extension" cards, by relaying).

Note :
- All the terminals are located at the bottom of the controller.
- Fit suppressors to all the specific circuits close to the controller or connected on the same circuit, such as relays, contactors, solenoid valves, fluorescent lighting, etc.

Compatible components (for complete references, consult our specialist catalogue)

Code	Description
Q1	GV2-L or Compact NS (see following pages)
KM2	LP4-●●●● (see following pages)

Variable speed controllers for asynchronous motors

Presentation :
 pages 60131/2 to 60131/6
 Characteristics :
 pages 60131/7 to 60131/9
 References :
 pages 60132/2 to 60132/4
 Functions :
 pages 60133/2 to 60133/25

Altivar 58

Schemes, compatibility

Speed controllers ATV-58HD16M2X to HD46M2X and HD28N4 to HD79N4

Schemes with downstream contactor, recommended for dangerous machines which are switched on and off frequently

3-phase supply

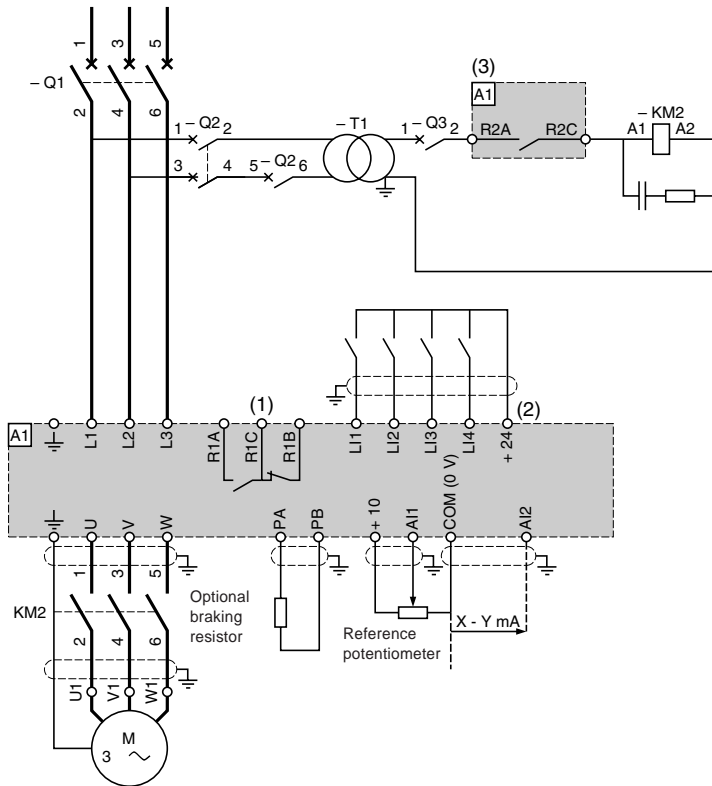

(1) Fault relay contacts; for remote signalling of speed controller status.

(2) Internal + 24 V. If an external + 24 V supply is used, connect the 0 V on the external supply to the COM terminal, do not use the + 24 of the speed controller, and connect the common of the LI inputs to the + 24 V of the external supply.

(3) Use the "downstream contactor control" function with relay R2 (or the logic output LO of one of the "I/O extension" cards, by relaying).

Note :

- All the terminals are located at the bottom of the controller.

- Fit suppressors to all the specific circuits close to the controller or connected on the same circuit, such as relays, contactors, solenoid valves, fluorescent lighting, etc.

Compatible components

Code	Description
Q1	GV2-L or Compact NS (see following pages)
KM2	LC1-D●●● with interference suppressor (see following pages)
T1	100 VA transformer 220 V secondary
Q2	GV2-L rated at twice the nominal primary current of T1
Q3	GB2-CB05

Variable speed controllers for asynchronous motors

Presentation :
 page 60139/2
 Characteristics :
 page 60139/2
 References :
 page 60139/3
 Functions :
 pages 60133/2 to 60133/25

Altivar 58

Schemes (continued)

24 V external supply for supplying logic inputs and/or the logic output

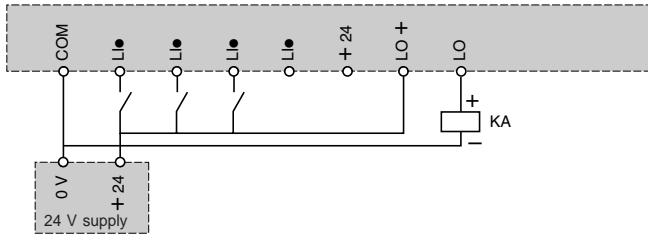

2-wire control and step by step (JOG) operation

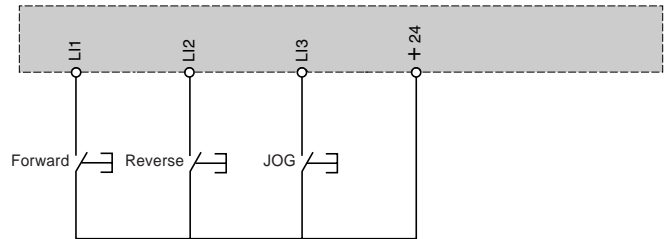

3-wire control and step by step (JOG) operation

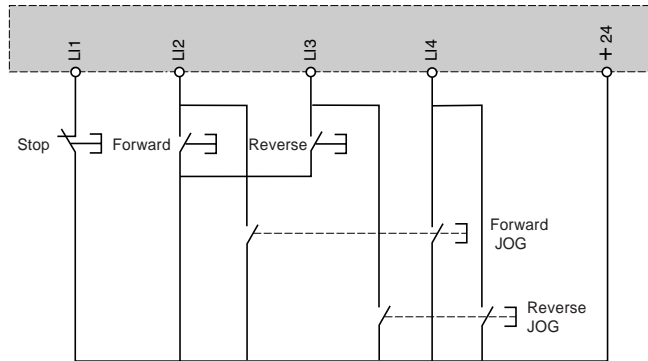

Motor protection via PTC probes, with optional analogue input extension card

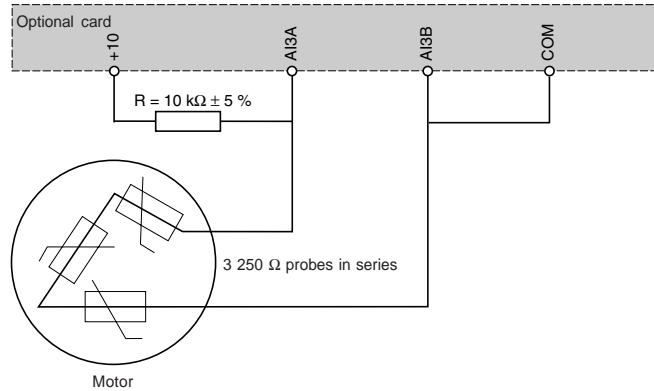

I/O extension card with analogue input
 VW3-A58201

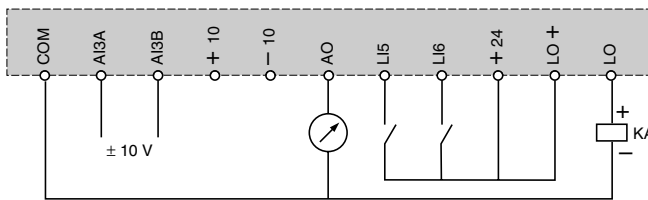

I/O extension card with inputs for encoder
 VW3-A58202

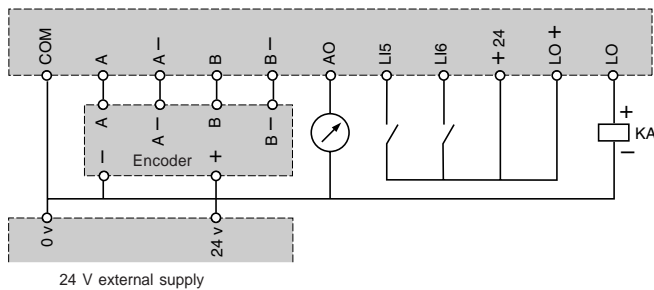

Variable speed controllers for asynchronous motors

Presentation :
 page 60139/2
 Characteristics :
 page 60139/2
 References :
 page 60139/3
 Functions :
 pages 60133/2 to 60133/25

Altivar 58

Schemes (continued)

Examples of use with I/O extension cards

VW3-A5820

Bipolar speed reference

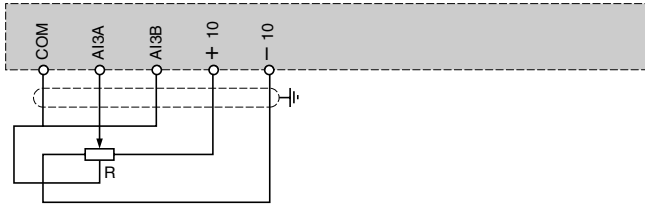

Bipolar speed reference on external ± 10 V supply

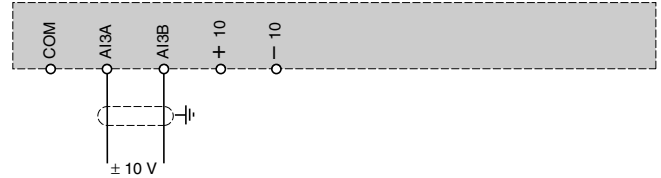

Unipolar speed reference

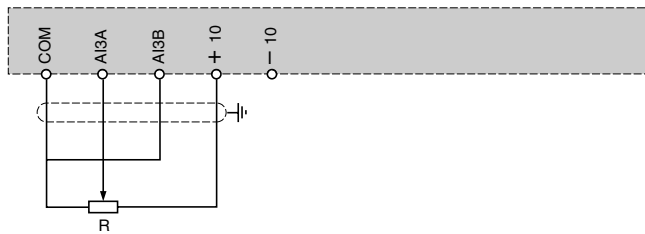

Speed regulation with tachometer feedback

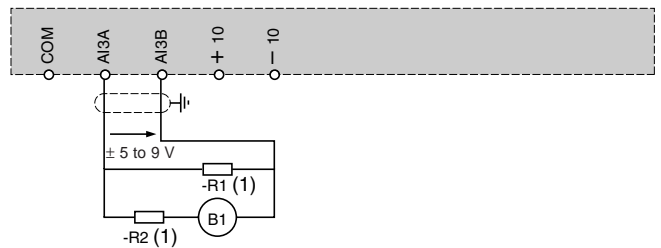

(1) See the section on functions to determine the resistances.

VW3-A58202 I/O extension card with inputs for encoder used with 3-wire inductive or photoelectric proximity sensor

Speed regulation with reduced precision at low speed and increased response time
 1 direction only

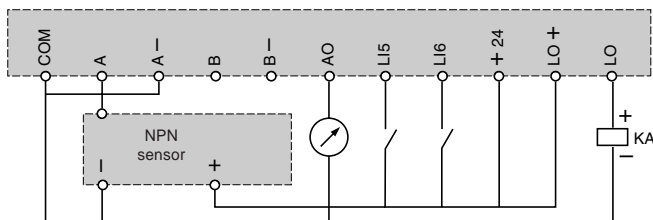

Variable speed controllers for asynchronous motors

Presentation :
 pages 60143/2 and 60144/2
 Characteristics :
 pages 60143/2 and 60144/3
 References :
 pages 60143/3 and 60144/3
 Dimensions :
 page 60134/5

Altivar 58

Schemes (continued)

Additional input filters, radio interference suppression filters

VW3-A5840●

Single phase supply, single phase filter

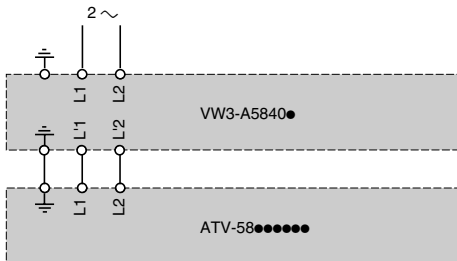

Single phase supply, 3-phase filters

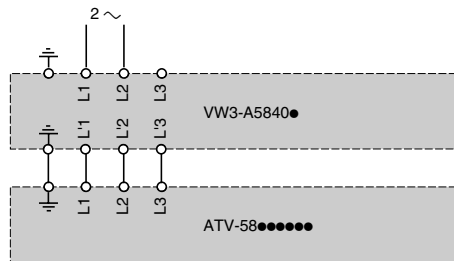

3-phase supply

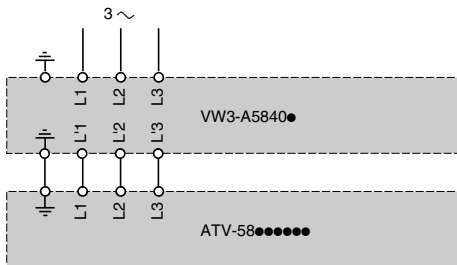

Output filters

VW3-A5845●

LR cell

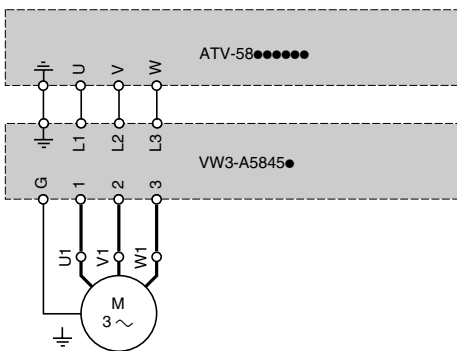

VW3-A6650● + VW3-A66421

Motor line chokes + capacitors

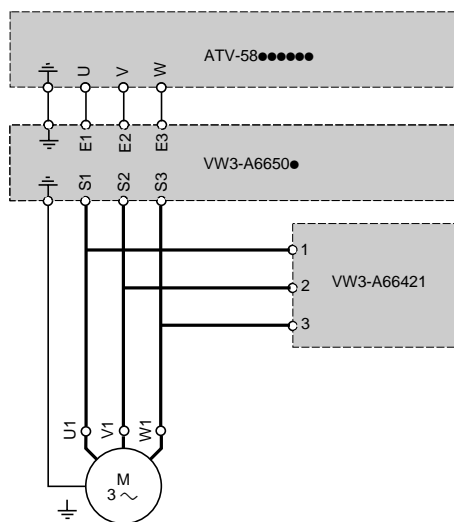

VW3-A6641●

LC cell

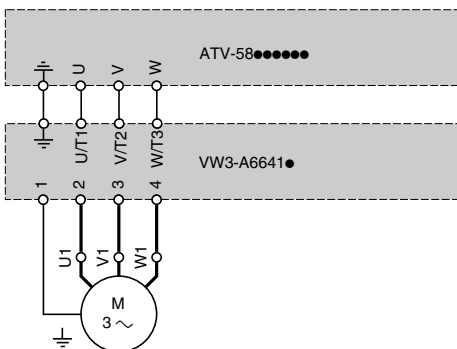

Variable speed controllers for asynchronous motors

Altivar 58 Electromagnetic compatibility

Principle, installation diagram

Presentation :
pages 60131/2 to 60131/6

Principle

- The earths between the speed controller, motor and cable shielding must have "high frequency" equipotentiality.
- Use shielded cables with shielding connected to earth at 360° at both ends of the motor cable, braking resistor (if fitted) and control-command cables. Tubes or metal ducting can be used for part of the shielding length provided that there is no break in continuity.
- Ensure maximum separation between the power supply cable (mains supply) and the motor cable.

Installation diagram

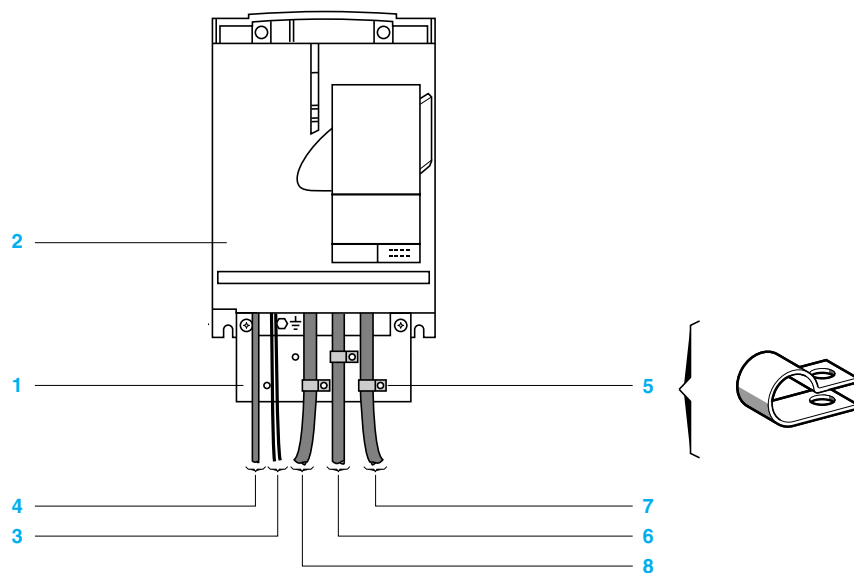

- 1 Metal plate supplied with the speed controller, to be mounted as shown (machine earth).
- 2 Altivar 58.
- 3 Non-shielded power supply wires or cable.
- 4 Non-shielded wires for fault relay contacts output.
- 5 Fix and earth the shielding of cables 6, 7 and 8 as close as possible to the speed controller :
 - strip the shielding
 - use the correct size clamps on the stripped part of the shielding to fix to metal plate 1.
The shielding must be clamped tightly enough to the metal plate to ensure good contact.
 - clamp types : stainless steel
- 6 Shielded cable for motor connection with shielding connected to earth at both ends.
The shielding must be continuous and intermediate terminal blocks must be in EMC shielded metal cases.
- 7 Shielded cable for connecting the control/command system.
For applications requiring several conductors, use small cross-sections (0.5 mm²).
The shielding must be connected to earth at both ends. The shielding must be continuous and intermediate terminal blocks must be in EMC shielded metal cases.
- 8 Shielded cable for connecting brake resistor (if fitted). The shielding must be connected to earth at both ends. The shielding must be continuous and intermediate terminal blocks must be in EMC shielded metal cases.

Notes :

- 1 The HF equipotential earth connection between the speed controller, motor and cable shielding does not remove the need to connect the PE protective conductors (green-yellow) to the appropriate terminals on each unit.
- 2 If using an additional input filter, it should be mounted under the speed controller (speed controller with heatsink) or to one side (speed controller on a baseplate), and connected directly to the mains supply via an unshielded cable. Link 3 is via the filter cable.

Variable speed controllers for asynchronous motors

Altivar 58
Motor starters

Combinations for customer assembly

Applications



GV2-L
+
LC1-D
+
ATV-58

- To protect people and property regardless of the level of overcurrent (overload or short-circuit).
- To reduce maintenance costs in the event of an incident by minimising the intervention time and the cost of replacing equipment.
- Used to isolate the motor on automatic stop via a line contactor or via a downstream contactor.

The combinations suggested provide **type 2 coordination**. That is, no damage or detriment is permitted. Isolation must be maintained after an incident, the motor starter must be able to operate after a short-circuit has been cleared. The risk of welding the line contactor (if used) contacts is permitted if they can be easily separated.

Before restarting the equipment, a quick inspection is sufficient.

Single phase supply voltage, 200 to 240 V (For motors 0.37 to 5.5 kW or 0.5 to 7.5 HP)

Motor circuit-breaker

NS80HMA : product marketed under the Merlin Gerin brand

Composition of contactors

LC1-K06 and LC1-D09 to LC1-D25 : 3-pole + 1 N/O auxiliary contact

LC1-D40 and LC1-D50 : 3-pole + 1 N/O auxiliary contact, + 1 N/C auxiliary contact

Standard powers of 3-phase 4-pole motors 50/60 Hz 230 V (1)	Circuit-breaker Reference	Rating	Max short-circuit current	Line contactor Basic reference to be completed by the voltage code (2)	24 V downstream contactor with coil Reference	Speed controller Reference to be completed (3)
kW	HP	A	kA			
0.37	0.5	GV2-L10	6.3	50	LC1-D1810●●	LP4-K0610BW3 ATV-58●U09M2
0.75	1	GV2-L14	10	50	LC1-D1810●●	LP4-K0610BW3 ATV-58●U18M2
1.5	2	GV2-L20	18	50	LC1-D2510●●	LP4-K0610BW3 ATV-58●U29M2
2.2	3	GV2-L22	25	50	LC1-D2510●●	LP4-K0610BW3 ATV-58●U41M2
3	-	GV2-L22	25	50	LC1-D2510●●	LP4-K0610BW3 ATV-58●U72M2 (4)
4	5	NS80HMA50	50	100	LC1-D4011●●	LP4-K0610BW3 ATV-58●U90M2 (4)
5.5	7.5	NS80HMA50	50	100	LC1-D5011●●	LP4-D1810BW3 ATV-58●D12M2 (4)

3-phase supply voltage, 200 to 230 V (For motors 1.5 to 7.5 kW or 2 to 10 HP)

Motor circuit-breaker

NS80HMA : product marketed under the Merlin Gerin brand

Composition of contactors

LC1-K06 and LC1-D09 to LC1-D25 : 3-pole + 1 N/O auxiliary contact

LC1 D40 and LC1-D50 : 3-pole + 1 N/O auxiliary contact, + 1 N/C auxiliary contact

Standard powers of 3-phase 4-pole motors 50/60 Hz 230 V (1)	Circuit-breaker Reference	Rating	Max short-circuit current	Line contactor Basic reference to be completed by the voltage code (2)	24 V downstream contactor with coil Reference	Speed controller Reference to be completed (3)
kW	HP	A	kA			
1.5	2	GV2-L14	10	50	LC1-D1810●●	LP4-K0610BW3 ATV-58●U29M2
2.2	3	GV2-L16	14	50	LC1-D1810●●	LP4-K0610BW3 ATV-58●U41M2
3	-	GV2-L20	18	50	LC1-D2510●●	LP4-K0610BW3 ATV-58●U54M2
4	5	GV2-L22	25	50	LC1-D2510●●	LP4-K0610BW3 ATV-58●U72M2
5.5	7.5	NS80HMA50	50	100	LC1-D4011●●	LP4-D1810BW3 ATV-58●U90M2
7.5	10	NS80HMA50	50	100	LC1-D5011●●	LP4-D2500BW3 ATV-58●D12M2 + LN1-D11

(1) The values expressed in HP conform to the NEC (National Electrical Code).

(2) Usual control circuit voltages.

a.c. control circuit

Volts ~	24	48	110	220/230	240
50/60 Hz	B7	E7	F7	M7	U7

Other voltages between 24 and 660 V, or d.c. control circuit, consult your Regional Sales Office.

(3) Replace the dot in the reference according to the type of speed controller required, see pages 60132/2 to 60132/4.

(4) A line choke must be added.

Variable speed controllers for asynchronous motors

Altivar 58
Motor starters

Combinations for customer assembly

3-phase supply voltage, 208 to 240 V (For motors 11 to 37 kW or 15 to 50 HP)



Motor circuit-breaker

NS●●●MA : product marketed under the Merlin Gerin brand

Composition of contactors

LC1-D32 : 3-pole + 1 N/O auxiliary contact

LC1-D40 and LC1-D115 : 3-pole + 1 N/O auxiliary contact, + 1 N/C auxiliary contact

Standard powers of 3-phase 4-pole motors 50/60 Hz 230 V (1) for applications				Circuit-breaker		Max short-circuit current	Line contactor Basic reference to be completed by the voltage code (2)	Downstream contactor Basic reference to be completed by the voltage code (2)	Speed controller Reference
Standard torque	High torque	Reference	Rating						
kW	HP	kW	HP	A	kA				
-	-	11	15	NS80HMA50	50	100	LC1-D4011●●	LC1-D3210●●	ATV-58HD16M2X
15	20	-	-	NS80HMA80	80	100	LC1-D6511●●	LC1-D4011●●	ATV-58HD16M2X
-	-	15	20	NS80HMA80	80	100	LC1-D6511●●	LC1-D4011●●	ATV-58HD23M2X
18.5	25	-	-	NS100NMA100	100	100	LC1-D8011●●	LC1-D5011●●	ATV-58HD23M2X
-	-	18.5	25	NS100NMA100	100	100	LC1-D8011●●	LC1-D5011●●	ATV-58HD28M2X
22	30	-	-	NS100NMA100	100	100	LC1-D8011●●	LC1-D8011●●	ATV-58HD28M2X
-	-	22	30	NS100NMA100	100	100	LC1-D8011●●	LC1-D8011●●	ATV-58HD33M2X
30	40	-	-	NS160NMA150	150	100	LC1-D115●●	LC1-D8011●●	ATV-58HD33M2X
-	-	30	40	NS160NMA150	150	100	LC1-D115●●	LC1-D8011●●	ATV-58HD46M2X
37	50	-	-	NS160NMA150	150	100	LC1-D115●●	LC1-D115●●	ATV-58HD46M2X

NS80HMA
+
LC1-D
+
ATV-58

(1) The values expressed in HP conform to the NEC (National Electrical Code).

(2) Usual control circuit voltages.
a.c. control circuit

Volts ~	24	48	110	220/230	240
50/60 Hz	B7	E7	F7	M7	U7

Other voltages between 24 and 660 V, or d.c. control circuit, consult your Regional Sales Office.

Variable speed controllers for asynchronous motors

Altivar 58
Motor starters

Combinations for customer assembly

3-phase supply voltage, 380 to 415 V (For motors 0.75 to 75 kW or 1 to 100 HP)



NS80HMA
+
LC1-D
+
ATV-58

Motor circuit-breaker

NS●●●●MA : product marketed under the Merlin Gerin brand

Composition of contactors

LC1-K06 and LC1-D09 to LC1-D32 : 3-pole + 1 N/O auxiliary contact

LC1-D40 to LC1-D115 : 3-pole + 1 N/O auxiliary contact, + 1 N/C auxiliary contact

Standard powers of 3-phase 4-pole motors 50/60 Hz 400 V (1) for applications				Circuit-breaker		Max short-circuit current	Line contactor Basic reference to be completed by the voltage code (2)	Downstream contactor (3) Reference	Speed controller Reference to be completed (4)
Standard torque		High torque		Reference	Rating				
kW	HP	kW	HP		A	kA			
–	–	0.75	1	GV2-L08	4	50	LC1-D1810●●	LP4-K0610BW3	ATV-58●U18N4
–	–	1.5	2	GV2-L10	6.3	50	LC1-D1810●●	LP4-K0610BW3	ATV-58●U29N4
–	–	2.2	3	GV2-L14	10	50	LC1-D1810●●	LP4-K0610BW3	ATV-58●U41N4
–	–	3	–	GV2-L16	14	50	LC1-D1810●●	LP4-K0610BW3	ATV-58●U54N4
–	–	4	5	GV2-L16	14	50	LC1-D1810●●	LP4-K0610BW3	ATV-58●U72N4
–	–	5.5	7.5	GV2-L22	25	50	LC1-D2510●●	LP4-K0610BW3	ATV-58●U90N4
–	–	7.5	10	NS80HMA50	50	25	LC1-D4011●●	LP4-K0610BW3	ATV-58●D12N4
–	–	11	15	NS80HMA50	50	25	LC1-D4011●●	LP4-D2500BW3	ATV-58●D16N4
–	–	15	20	NS80HMA50	50	25	LC1-D5011●●	LP4-D2500BW3 + LN1D11	ATV-58●D23N4
–	–	18.5	25	NS80HMA50	50	35	LC1-D4011●●	LC1-D2510●●	ATV-58HD28N4
22	30	–	–	NS80HMA50	50	35	LC1-D4011●●	LC1-D3210●●	ATV-58HD28N4
–	–	22	30	NS80HMA80	80	35	LC1-D6511●●	LC1-D3210●●	ATV-58HD33N4
30	40	–	–	NS80HMA80	80	35	LC1-D6511●●	LC1-D4011●●	ATV-58HD33N4
–	–	30	40	NS80HMA80	80	35	LC1-D6511●●	LC1-D5011●●	ATV-58HD46N4
37	50	–	–	NS80HMA80	80	35	LC1-D6511●●	LC1-D5011●●	ATV-58HD46N4
–	–	37	50	NS100NMA100	100	25	LC1-D8011●●	LC1-D5011●●	ATV-58HD54N4
45	60	–	–	NS100NMA100	100	25	LC1-D8011●●	LC1-D8011●●	ATV-58HD54N4
–	–	45	60	NS160NMA150	150	35	LC1-D115●●	LC1-D8011●●	ATV-58HD64N4
55	75	–	–	NS160NMA150	150	35	LC1-D115●●	LC1-D8011●●	ATV-58HD64N4
–	–	55	75	NS160NMA150	150	35	LC1-D115●●	LC1-D8011●●	ATV-58HD79N4
75	100	–	–	NS160NMA150	150	35	LC1-D115●●	LC1-D115●●	ATV-58HD79N4

(1) The values expressed in HP conform to the NEC (National Electrical Code).

(2) Usual control circuit voltages.

a.c. control circuit

Volts ~	24	48	110	220/230	240
50/60 Hz	B7	E7	F7	M7	U7

Other voltages between 24 and 660 V, or d.c. control circuit, consult your Regional Sales Office.

(3) LP4 contactors have a 24 V d.c. coil as they are supplied by the speed controller's internal supply. The basic reference of LC1 contactors should be completed by the voltage code (2).

(4) Replace the dot in the reference according to the type of speed controller required, see pages 60132/2 to 60132/4.

Variable speed controllers for asynchronous motors

Altivar 58
Motor starters

Combinations for customer assembly

3-phase supply voltage, 440 to 500 V (For motors 0.75 to 75 kW or 1 to 100 HP)



NS80HMA
+
LC1-D
+
ATV-58

Motor circuit-breaker

NS●●●MA : product marketed under the Merlin Gerin brand

Composition of contactors

LC1-K06 and LC1-D09 to LC1-D32 : 3-pole + 1 N/O auxiliary contact

LC1-D40 to LC1-D115 : 3-pole + 1 N/O auxiliary contact, + 1 N/C auxiliary contact

Standard powers of 3-phase 4-pole motors 50/60 Hz 400 V (1) for applications				Circuit-breaker		Max short-circuit current	Line contactor Basic reference to be completed by the voltage code (2)	Downstream contactor (3) Reference	Speed controller Reference to be completed (4)
Standard torque				Reference	Rating				
kW	HP	kW	HP	A	KA				
–	–	0.75	1	GV2-L08	4	50	LC1-D1810●●	LP4-K0610BW3	ATV-58●U18N4
–	–	1.5	2	GV2-L10	6.3	50	LC1-D2510●●	LP4-K0610BW3	ATV-58●U29N4
–	–	2.2	3	GV2-L10	6.3	50	LC1-D2510●●	LP4-K0610BW3	ATV-58●U41N4
–	–	3	–	GV2-L14	10	10	LC1-D2510●●	LP4-K0610BW3	ATV-58●U54N4
–	–	4	5	GV2-L14	10	10	LC1-D2510●●	LP4-K0610BW3	ATV-58●U72N4
–	–	5.5	7.5	NS80HMA50	50	25	LC1-D4011●●	LP4-K0610BW3	ATV-58●U90N4
–	–	7.5	10	NS80HMA50	50	25	LC1-D4011●●	LP4-K0610BW3	ATV-58●D12N4
–	–	11	15	NS80HMA50	50	25	LC1-D4011●●	LP4-D1810BW3	ATV-58●D16N4
–	–	15	20	NS80HMA50	50	25	LC1-D4011●●	LP4-D2500BW3 + LN1D11	ATV-58●D23N4
–	–	18.5	25	NS100LMA50	50	100	LC1-D8011●●	LC1-D2510●●	ATV-58HD28N4
22	30	–	–	NS100LMA50	50	100	LC1-D8011●●	LC1-D3210●●	ATV-58HD28N4
–	–	22	30	NS100LMA50	50	100	LC1-D8011●●	LC1-D3210●●	ATV-58HD33N4
30	40	–	–	NS100LMA50	50	100	LC1-D8011●●	LC1-D4011●●	ATV-58HD33N4
–	–	30	40	NS100LMA100	100	100	LC1-D8011●●	LC1-D5011●●	ATV-58HD46N4
37	50	–	–	NS100LMA100	100	100	LC1-D8011●●	LC1-D5011●●	ATV-58HD46N4
–	–	37	50	NS100LMA100	100	100	LC1-D8011●●	LC1-D5011●●	ATV-58HD54N4
45	60	–	–	NS100LMA100	100	100	LC1-D8011●●	LC1-D8011●●	ATV-58HD54N4
–	–	45	60	NS100LMA100	100	100	LC1-D115●●	LC1-D8011●●	ATV-58HD64N4
55	75	–	–	NS100LMA100	100	100	LC1-D115●●	LC1-D8011●●	ATV-58HD64N4
–	–	55	75	NS160LMA150	150	100	LC1-D115●●	LC1-D8011●●	ATV-58HD79N4
75	100	–	–	NS160LMA150	150	100	LC1-D115●●	LC1-D115●●	ATV-58HD79N4

(1) The values expressed in HP conform to the NEC (National Electrical Code).

(2) Usual control circuit voltages.

a.c. control circuit

Volts ~	24	48	110	220/230	240
50/60 Hz	B7	E7	F7	M7	U7

Other voltages between 24 and 660 V, or d.c. control circuit, consult your Regional Sales Office.

(3) LP4 contactors have a 24 V d.c. coil as they are supplied by the speed controller's internal supply. The basic reference of LC1 contactors should be completed by the voltage code (2).

(4) Replace the dot in the reference according to the type of speed controller required, see pages 60132/2 to 60132/4.

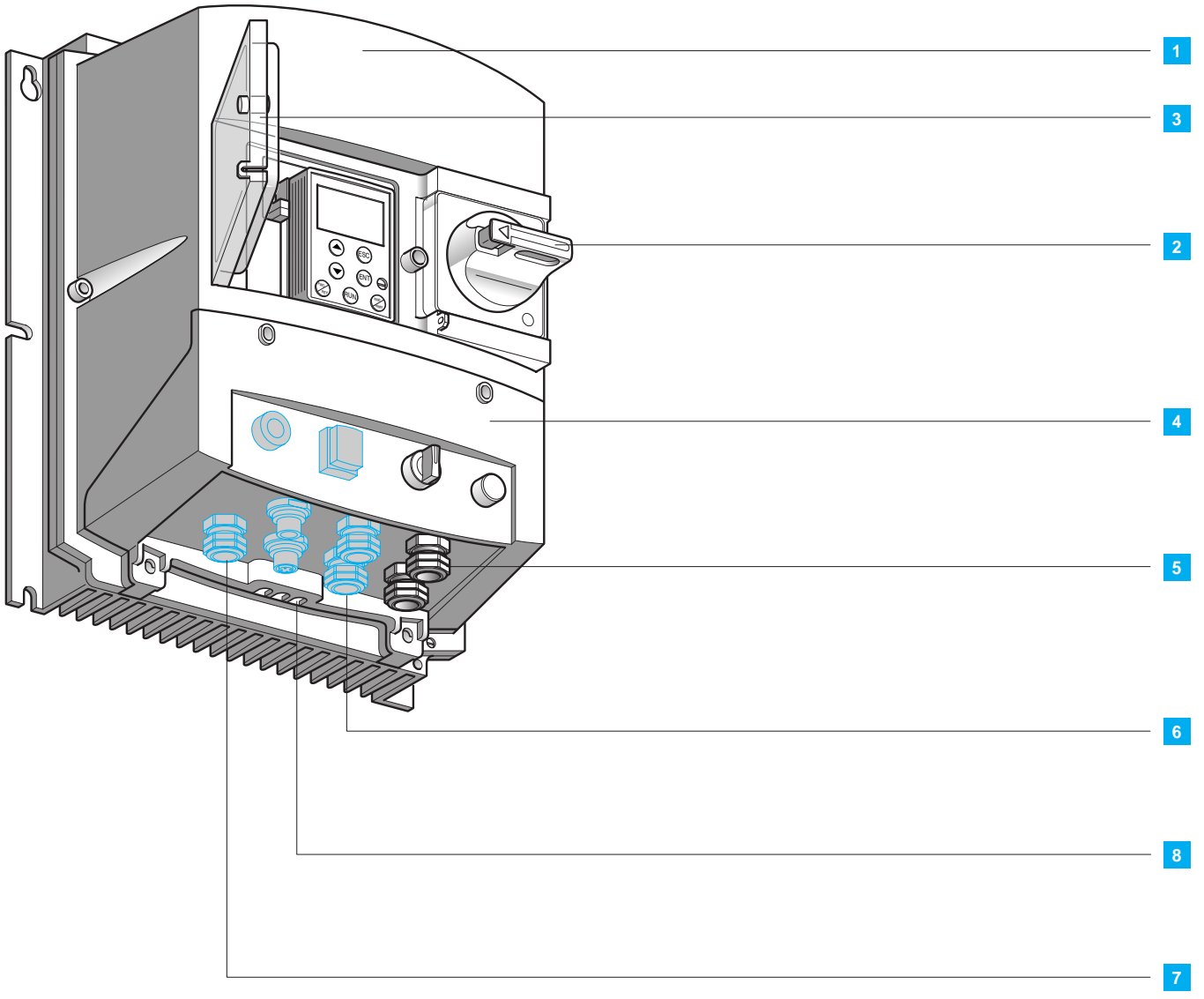

Variable speed controllers for asynchronous motors

References :
pages 60172/2 and 60172/3
Dimensions :
page 60173/2
Schemes :
page 60173/3
Functions :
pages 60133/2 to 60133/25

Ready-assembled Altivar 58

Description

Description

Altivar 58 COMPACT (ready-assembled speed controllers with power ratings ≤ 5.5 KW)

Ready-assembled speed controllers with power ratings between 0.37 and 5.5 kW are housed in dust and damp proof enclosures **1** and comprise an ATV-58 speed controller, a protective circuit-breaker with a padlockable handle **2** and a downstream contactor.

A transparent cover **3**, which can be opened and through which indicator lights and the operator terminal can be seen. The cover can be lead sealed.

The cover can only be opened if the circuit-breaker is tripped manually using **2**.

The metal cable clamp **4** consists of :

- On the front panel :
 - a 3-position switch for selecting the direction of operation (factory wired for only one direction)
 - a "frequency" reference potentiometer (which can be replaced by a plug supplied in the package) for optional remote control
 - 2 slots for optional control units (diameter 16)
- Underneath :
 - 2 holes equipped with EMC PG13 metal cable glands **5** (one for the shielded motor cable, the other for the "control or braking" shielded cable, if used)
 - 2 holes plugged with plastic plugs, intended for PG11 cable gland **6** (mains power supply unshielded cables and R1 relay contacts)
 - 3 recesses for additional cabling **7**.
 - 3 open cut-outs **8** equipped with plugs, through which cables equipped with connectors can be passed (PC link, remote terminal, communication bus) without the need to remove the connectors

Plug-in connections are used to link the cabling clamp and the devices inside the enclosure, enabling the active elements to be replaced quickly.

The unit is supplied ready for operation, with the "Forward" command prewired internally.

Options

- Standard options : the ready-assembled Altivar 58 can accept the options which are standard to the ATV-58 range :
 - extension cards
 - communication cards
 - programming terminal
 - PC software
 - braking module and resistors, to be mounted externally
- Special options for power ratings ≤ 5.5 kW :
 - line choke to be mounted externally
 - IP 65 enclosure for remote location of the operator terminal
 - prewired plug-in connector for AS-i bus (to be mounted on **7**)
 - prewired plug-in connector for connecting a sensor (to be mounted on **7**)
 - additional internal plug-in control terminal block for remote control

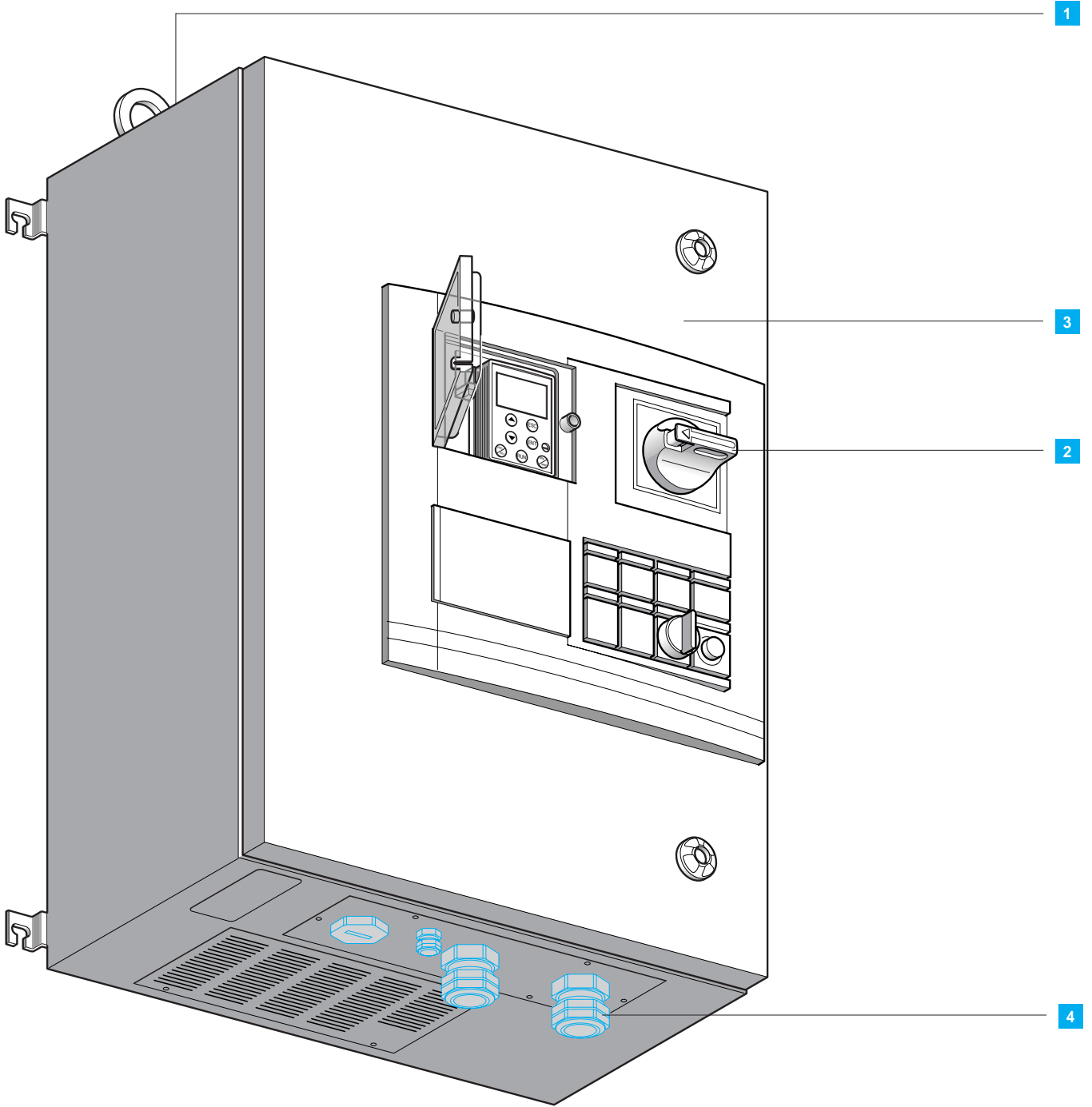

Variable speed controllers for asynchronous motors

References :
pages 60172/2 and 60172/3
Dimensions :
page 60173/2
Schemes :
page 60173/3
Functions :
pages 60133/2 to 60133/25

Ready-assembled Altivar 58

Description

Description

Altivar 58 ENERGY (ready-assembled speed controllers with power ratings ≤ 7.5 KW)

Ready-assembled speed controllers with power ratings ≤ 7.5 kW are housed in dust and damp proof enclosures **1** and comprise an ATV-58 speed controller, a line choke, a Vario isolator switch with an external padlockable front control button **2**, a "frequency" reference potentiometer, a 3-position switch for selecting the direction of operation and an operator terminal (if used).

There is a slot for installing an additional contactor.

The front panel has a hinged cover **3**. For safety reasons, it can only be opened if the isolator switch is in the "power off" position.

The underside of the enclosure is fitted with cable glands **4** to allow the cables to pass through.

On delivery, ready-assembled speed controllers with power ratings ≥ 7.5 kW must be wired in line with or downstream of the additional contactor, following the instructions supplied.

Options

- Common options : the ready-assembled Altivar 58 can accept the options which are common to the ATV-58 range :
 - extension cards
 - communication cards
 - programming terminal
 - PC software
 - braking module and resistors, to be mounted externally
- Special options for power ratings ≥ 7.5 kW :
 - IP 65 enclosure for remote location of the operator terminal
 - line contactor or downstream contactor
 - SUB-D cable gland

Characteristics

The ready-assembled Altivar 58 has the same environmental, drive and electrical characteristics as the Altivar 58 with heatsink and on baseplate, with the exception of :

Degree of protection			IP 55
Ambient air temperature around the unit	Storage	°C	- 25...+ 65
	Operation	°C	- 10...+ 40
Shock resistance	Conforming to IEC 68-2-27		10 g for 11 ms

Variable speed controllers for asynchronous motors

Altivar 58
Ready-assembled

Possible combinations

Combinations (see pages 60172/2 and 60172/3)

Altivar 58 COMPACT

Mains supply Supply voltage 50/60 Hz	Motor Power indicated on rating plate		ATV-58 speed controller for applications		Options				
	kW	HP	standard torque (120 % Tn)	high torque (170 % Tn)	Line choke See p. 60142/3	1 extension or communication card See p. 60139/3 See p. 60140/3	IP65 enclosure for remote operator terminal See p. 60172/3	Programming terminal (1) See p. 60138/2	PC interconnection See p. 60138/3
200...240 V single phase	0.37	0.5	–	ATV-58EU09M2	VZ1-L004M010	VW3-A58●●●	VW3-A58864	VW3-A58102L●	VW3-A58104
	0.75	1	–	ATV-58EU18M2	VZ1-L007UM50	VW3-A58●●●	VW3-A58864	VW3-A58102L●	VW3-A58104
	1.5	2	–	ATV-58EU29M2	VZ1-L018UM20	VW3-A58●●●	VW3-A58864	VW3-A58102L●	VW3-A58104
	2.2	3	–	ATV-58EU41M2	VZ1-L018UM20	VW3-A58●●●	VW3-A58864	VW3-A58102L●	VW3-A58104
200...240 V 3-phase	1.5	2	–	ATV-58EU29M2	VW3-A66502	VW3-A58●●●	VW3-A58864	VW3-A58102L●	VW3-A58104
	2.2	3	–	ATV-58EU41M2	VW3-A66503	VW3-A58●●●	VW3-A58864	VW3-A58102L●	VW3-A58104
380...500 V 3-phase	0.75	1	–	ATV-58EU18N4	VW3-A66501	VW3-A58●●●	VW3-A58864	VW3-A58102L●	VW3-A58104
	1.5	2	–	ATV-58EU29N4	VW3-A66501	VW3-A58●●●	VW3-A58864	VW3-A58102L●	VW3-A58104
	2.2	3	–	ATV-58EU41N4	VW3-A66502	VW3-A58●●●	VW3-A58864	VW3-A58102L●	VW3-A58104
	3	–	–	ATV-58EU54N4	VW3-A66502	VW3-A58●●●	VW3-A58864	VW3-A58102L●	VW3-A58104
	4	5	–	ATV-58EU72N4	VW3-A66502	VW3-A58●●●	VW3-A58864	VW3-A58102L●	VW3-A58104
	5.5	7.5	–	ATV-58EU90N4	VW3-A66503	VW3-A58●●●	VW3-A58864	VW3-A58102L●	VW3-A58104

Altivar 58 ENERGY

Mains supply Supply voltage 50/60 Hz	Motor Power indicated on rating plate		ATV-58 speed controller for applications		Options					
	kW	HP	standard torque (120 % Tn)	high torque (170 % Tn)	Line choke See p. 60142/3	1 extension or communication card See p. 60139/3 See p. 60140/3	IP65 enclosure for remote operator terminal See p. 60172/3	Programming terminal (1) See p. 60138/2	PC interconnection See p. 60138/3	
380...500V 3-phase	7.5	10	–	ATV-58ED12N4	Integrated	VW3-A58●●●	VW3-A58864	VW3-A58102L●	VW3-A58104	
	11	15	–	ATV-58ED16N4	Integrated	VW3-A58●●●	VW3-A58864	VW3-A58102L●	VW3-A58104	
	15	20	–	ATV-58ED23N4	Integrated	VW3-A58●●●	VW3-A58864	VW3-A58102L●	VW3-A58104	
	18.5	25	–	ATV-58ED28N4	Integrated	VW3-A58●●●	VW3-A58864	VW3-A58102L●	VW3-A58104	
	22	30	–	ATV-58ED33N4	Integrated	VW3-A58●●●	VW3-A58864	VW3-A58102L●	VW3-A58104	
				ATV-58ED28N4	–	Integrated	VW3-A58●●●	VW3-A58864	VW3-A58102L●	VW3-A58104
	30	40	–	ATV-58ED46N4	Integrated	VW3-A58●●●	VW3-A58864	VW3-A58102L●	VW3-A58104	
				ATV-58ED33N4	–	Integrated	VW3-A58●●●	VW3-A58864	VW3-A58102L●	VW3-A58104
	37	50	–	ATV-58ED54N4	Integrated	VW3-A58●●●	VW3-A58864	VW3-A58102L●	VW3-A58104	
				ATV-58ED46N4	–	Integrated	VW3-A58●●●	VW3-A58864	VW3-A58102L●	VW3-A58104
	45	60	–	ATV-58ED64N4	Integrated	VW3-A58●●●	VW3-A58864	VW3-A58102L●	VW3-A58104	
				ATV-58ED54N4	–	Integrated	VW3-A58●●●	VW3-A58864	VW3-A58102L●	VW3-A58104
	55	75	–	ATV-58ED79N4	Integrated	VW3-A58●●●	VW3-A58864	VW3-A58102L●	VW3-A58104	
				ATV-58ED64N4	–	Integrated	VW3-A58●●●	VW3-A58864	VW3-A58102L●	VW3-A58104
	75	100	–	ATV-58ED79N4	Integrated	VW3-A58●●●	VW3-A58864	VW3-A58102L●	VW3-A58104	

(1) Reference to be completed depending on the language required : 1 for English, Spanish and French ; 2 for German, English and Italian.

(2) In most cases this filter is of no advantage, as the ready-assembled speed controller can be placed very close to the motor.

RS 485 interconnection	Additional input filter (2)	Output filter (2)	Braking module	IP 00 braking resistor	IP 30 braking resistor	Plug-in connector for AS-i bus	Plug-in connector for sensor	Plug-in control terminal block for remote control
See p. 60138/3	See p. 60143/3	See p. 60144/3	See p. 60141/4	See p. 60141/4	See p. 60141/5	See p. 60172/3	See p. 60172/3	See p. 60172/3
VW3-A58306	VW3-A58401	–	VW3-A58701	VW3-A58702	VW3-A58732	VW3-A58862	VW3-A58863	VW3-A58861
VW3-A58306	VW3-A58401	VW3-A58451	VW3-A58701	VW3-A58702	VW3-A58732	VW3-A58862	VW3-A58863	VW3-A58861
VW3-A58306	VW3-A58402	VW3-A58451	Integrated	VW3-A58702	VW3-A58732	VW3-A58862	VW3-A58863	VW3-A58861
VW3-A58306	VW3-A58402	VW3-A58452	Integrated	VW3-A58704	VW3-A58733	VW3-A58862	VW3-A58863	VW3-A58861
VW3-A58306	VW3-A58402	VW3-A58451	Integrated	VW3-A58702	VW3-A58732	VW3-A58862	VW3-A58863	VW3-A58861
VW3-A58306	VW3-A58402	VW3-A58452	Integrated	VW3-A58704	VW3-A58733	VW3-A58862	VW3-A58863	VW3-A58861
VW3-A58306	VW3-A58402	VW3-A58451	Integrated	VW3-A58702	VW3-A58732	VW3-A58862	VW3-A58863	VW3-A58861
VW3-A58306	VW3-A58402	VW3-A58451	Integrated	VW3-A58702	VW3-A58732	VW3-A58862	VW3-A58863	VW3-A58861
VW3-A58306	VW3-A58402	VW3-A58451	Integrated	VW3-A58702	VW3-A58732	VW3-A58862	VW3-A58863	VW3-A58861
VW3-A58306	VW3-A58403	VW3-A58451	Integrated	VW3-A58703	VW3-A58734	VW3-A58862	VW3-A58863	VW3-A58861
VW3-A58306	VW3-A58403	VW3-A58451	Integrated	VW3-A58703	VW3-A58734	VW3-A58862	VW3-A58863	VW3-A58861
VW3-A58306	VW3-A58403	VW3-A58452	Integrated	–	VW3-A58735	VW3-A58862	VW3-A58863	VW3-A58861

RS 485 interconnection	Additional input filter (2)	Output filter (2)	Braking module	IP 00 braking resistor	IP 30 braking resistor	Plug-in connector for AS-i bus	Plug-in connector for sensor	Plug-in control terminal block for remote control
See p. 60138/3	See p. 60143/3	See p. 60144/3	See p. 60141/4	See p. 60141/4	See p. 60141/5	See p. 60172/3	See p. 60172/3	See p. 60172/3
VW3-A58306	VW3-A58404	VW3-A58452	Integrated	–	VW3-A58735	–	–	–
VW3-A58306	VW3-A58404	VW3-A58452	Integrated	–	VW3-A58736	–	–	–
VW3-A58306	VW3-A58405	VW3-A58453	Integrated	–	VW3-A58736	–	–	–
VW3-A58306	–	VW3-A66412	Integrated	–	VW3-A58737	–	–	–
VW3-A58306	–	VW3-A66412	Integrated	–	VW3-A58737	–	–	–
VW3-A58306	–	VW3-A66412	Integrated	–	VW3-A58737	–	–	–
VW3-A58306	–	VW3-A66412	Integrated	–	VW3-A58737	–	–	–
VW3-A58306	–	VW3-A66412	Integrated	–	VW3-A58737	–	–	–
VW3-A58306	–	VW3-A66413	Integrated	–	VW3-A66704	–	–	–
VW3-A58306	–	VW3-A66413	Integrated	–	VW3-A58737	–	–	–
VW3-A58306	–	VW3-A66413	Integrated	–	VW3-A66704	–	–	–
VW3-A58306	–	VW3-A66413	Integrated	–	VW3-A66704	–	–	–
VW3-A58306	–	VW3-A66413	Integrated	–	VW3-A66704	–	–	–
VW3-A58306	–	VW3-A66413	Integrated	–	VW3-A66704	–	–	–
VW3-A58306	–	–	Integrated	–	VW3-A66704	–	–	–

Variable speed controllers for asynchronous motors

Description, characteristics :
pages 60170/2 to 60170/5
Dimensions:
page 60173/2
Schemes :
page 60173/3
Functions :
pages 60133/2 to 60133/25

Ready-assembled Altivar 58
for asynchronous motors from 0.37 to 75 kW or 0.5 to 100 HP

References

High torque applications (170 % Tn)

Motor Power indicated on rating plate (1)	Mains supply Line current (2)				Prospective line Isc		Altivar 58		Reference to be completed (4)	Weight
	at U min	at U max	at U min	at U max	Contin. output current A	Max transient current (3) A				
kW	HP	A	A	kA	kA	A	A		kg	
Single phase supply voltage : 200...240 V (5) 50/60 Hz										
0.37	0.5	5.6	4.7	2	2	2.3	3.1	ATV-58EU09M2	9.500	
0.75	1	9.8	8.3	2	2	4.1	5.6	ATV-58EU18M2	9.500	
1.5	2	18.5	15.6	5	5	7.8	10.6	ATV-58EU29M2	10.500	
2.2	3	24.8	21.1	5	5	11	15	ATV-58EU41M2	19.500	
3-phase supply voltage : 200...240 V (5) 50/60 Hz										
1.5	2	9.7	8.3	5	5	7.8	10.6	ATV-58EU29M2	10.500	
2.2	3	13.4	11.4	5	5	11	15	ATV-58EU41M2	19.500	
3-phase supply voltage : 380...500 V (5) 50/60 Hz										
0.75	1	3.4	2.6	5	5	2.3	3.1	ATV-58EU18N4	10.500	
1.5	2	6	4.5	5	5	4.1	5.6	ATV-58EU29N4	10.500	
2.2	3	7.8	6	5	5	5.8	7.9	ATV-58EU41N4	10.500	
3	-	10.2	7.8	5	5	7.8	10.6	ATV-58EU54N4	19.500	
4	5	13	10.1	5	5	10.5	14.3	ATV-58EU72N4	19.500	
5.5	7.5	17	13.2	5	5	13	17.7	ATV-58EU90N4	19.500	
7.5	10	17.5	14	22	22	17.6	24	ATV-58ED12N4	43.000	
11	15	24	20	22	22	24.2	32.9	ATV-58ED16N4	43.000	
15	20	29.5	25.5	22	22	33	44.9	ATV-58ED23N4	46.000	
18.5	25	43	35	22	65	41	55	ATV-58ED28N4	70.000	
22	30	51	41	22	65	48	66	ATV-58ED33N4	70.000	
30	40	68	55	22	65	66	90	ATV-58ED46N4	70.000	
37	50	82	66	22	65	79	108	ATV-58ED54N4	110.000	
45	60	101	82	22	65	94	127	ATV-58ED64N4	110.000	
55	75	121	98	22	65	116	157	ATV-58ED79N4	110.000	



ATV-58EU09M2



ATV-58ED12N4

Standard torque applications (120 % Tn)

3-phase supply voltage : 380...500 V (5) 50/60 Hz										
22	30	51	41	22	65	44	55	ATV-58ED28N4	70.000	
30	40	67	53	22	65	60	66	ATV-58ED33N4	70.000	
37	50	82	66	22	65	72	90	ATV-58ED46N4	70.000	
45	60	99	79	22	65	85	108	ATV-58ED54N4	110.000	
55	75	121	97	22	65	105	127	ATV-58ED64N4	110.000	
75	100	160	130	22	65	138	157	ATV-58ED79N4	110.000	

(1) These power ratings are given for a maximum switching frequency of 4 kHz, in continuous use, without derating. For higher switching frequencies, these values are for intermittent duty only, alternatively the speed controller must be derated by one rating. See special applications on page 60131/11.

(2) Typical value without additional choke.

(3) For 60 seconds.

(4) Speed controller supplied with operator terminal. To obtain a speed controller without an operator terminal, add a Z at the end of the reference.

Example : ATV-58EU09M2 without operator terminal becomes ATV-58EU09M2Z.

(5) Nominal supply voltage, U min...U max.

Variable speed controllers for asynchronous motors

Description, characteristics :
pages 60170/2 to 60170/5
Dimensions :
page 60173/2
Schemes :
page 60173/3
Functions :
pages 60133/2 to 60133/25

Ready-assembled Altivar 58
Special options

References

IP 65 enclosure for remote location of operator terminal

The plug-in terminal can be used remotely, hand-held or fixed to the machine, using this IP 65 dust and damp proof kit.

Description	For speed controllers	Reference	Weight kg
Kit comprising : - 1 cable with connectors, length 3 m - IP 65 enclosure with flexible, transparent membrane - manual	ATV-58E all ratings	VW3-A58864	0.300

M12 prewired plug-in connectors

Description	For speed controllers	Reference	Weight kg
4-way straight male M12 connector for AS-i bus	ATV-58E ratings ≤ 5.5 kW	VW3-A58862	0.100
5-way female M12 connector for sensor	ATV-58E ratings ≤ 5.5 kW	VW3-A58863	0.100

Additional plug-in control terminal block for remote control

Description	For speed controllers	Reference	Weight kg
10-pin plug-in internal terminal block cross-section 2.5 mm maximum	ATV-58E ratings ≤ 5.5 kW	VW3-A58861	0.100

Line choke

The line choke must be mounted externally for speed controllers with power ratings ≤ 5.5 kW. It is built into speed controllers with power ratings ≥ 7.5 kW.

To select a line choke, see page 60142/3.

Line or downstream contactor

On speed controllers with power ratings ≥ 7.5 kW, a slot is provided for mounting a contactor. The contactor is wired as a line or downstream contactor by the user, depending on requirements.

To select a contactor, see pages 60136/2 to 60136/5.

Potentiometer

Description	For speed controllers	Reference	Weight kg
IP 65 potentiometer 2.2 k Ω	ATV-58E all ratings	VW3-A58866	0.100

SUB-D cable gland

Description	For speed controllers	Reference	Weight kg
SUB-D cable gland	ATV-58E power ratings ≥ 7.5 kW	VW3-A58865	0.300

Variable speed controllers for asynchronous motors

Description, characteristics :
 pages 60170/2 to 60170/5
 References :
 pages 60172/2 and 60172/3
 Schemes :
 page 60173/3
 Functions :
 pages 60133/2 to 60133/25

Ready-assembled Altivar 58

Dimensions

Dimensions

ATV-58EU●●●●

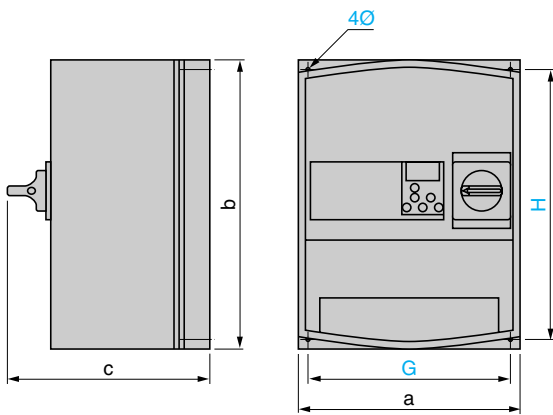

ATV-58ED●●●●

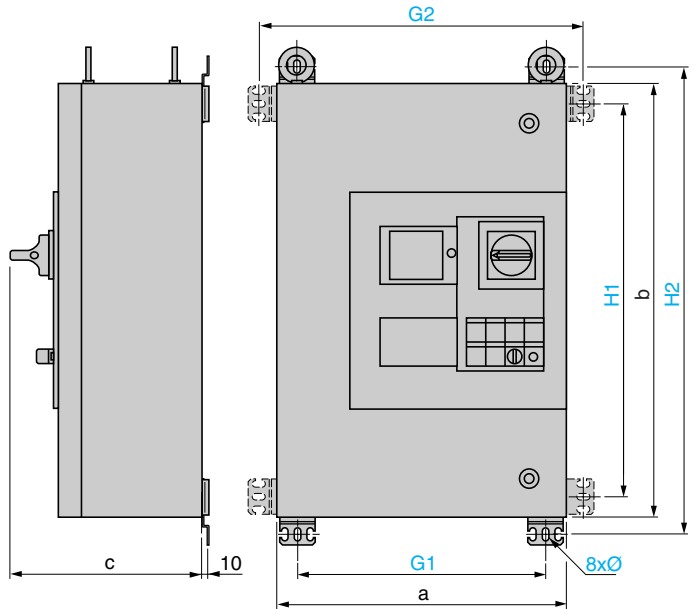

ATV-58E	a	b	c	G	H	Ø
U09M2, U18M2	230	316	215	210	300	5.5
U29M2, U18N4, U29N4, U41N4	270	337	250	250	322	5.5
U41M2, U54N4, U72N4, U90N4	300	406	281	280	391	5.5

ATV-58E	a	b	c	G1	G2	H1	H2	Ø
D12N4, D16N4, D23N4	500	700	300.5	437.5	550	637.5	750	9
D28N4, D33N4, D46N4	460	850	365.5	397.5	510	787.5	900	9
D54N4, D64N4, D79N4	570	1050	405.5	507.5	620	987.5	1100	9

Mounting precautions

ATV-58EU●●●●

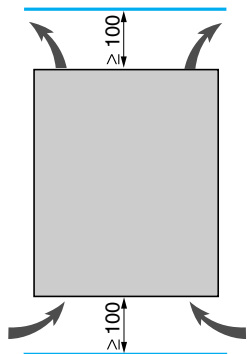

ATV-58ED●●●●

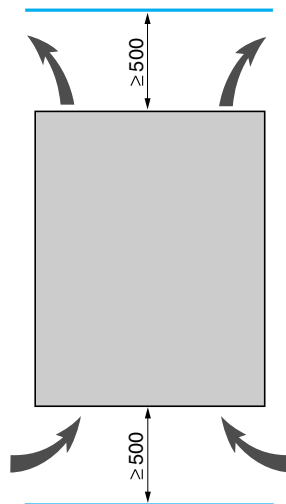

Do not place the device near heating elements.

Leave sufficient clearance to allow air circulation. The speed controller is cooled by an air flow from the bottom to the top.

Variable speed controllers for asynchronous motors

Description, characteristics :
 pages 60170/2 to 60170/5
 References :
 pages 60172/2 and 60172/3
 Dimensions :
 page 60173/2
 Functions :
 pages 60133/2 to 60133/25

Ready-assembled Altivar 58

Schemes

Schemes

ATV-58EU09M2, EU18M2

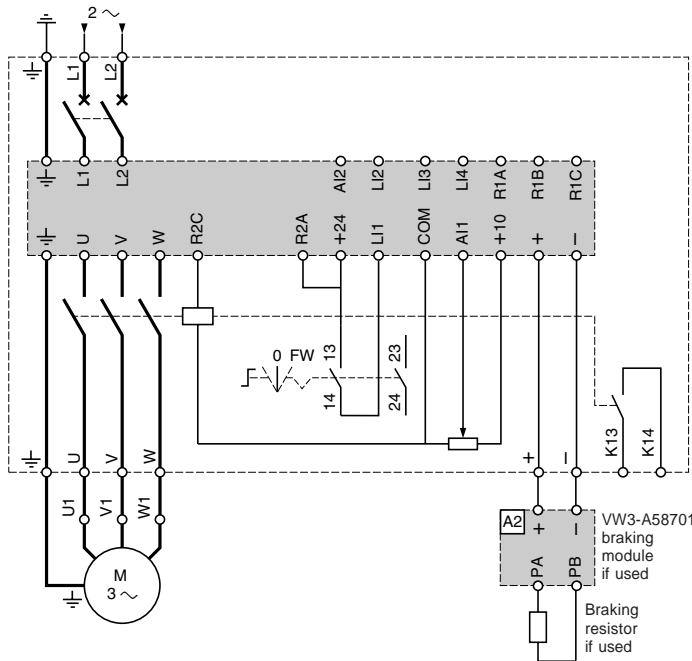

ATV-58EU29M2, EU41M2, EU18N4, EU29N4, EU41N4, EU54N4, ATV-58EU72N4, EU90N4

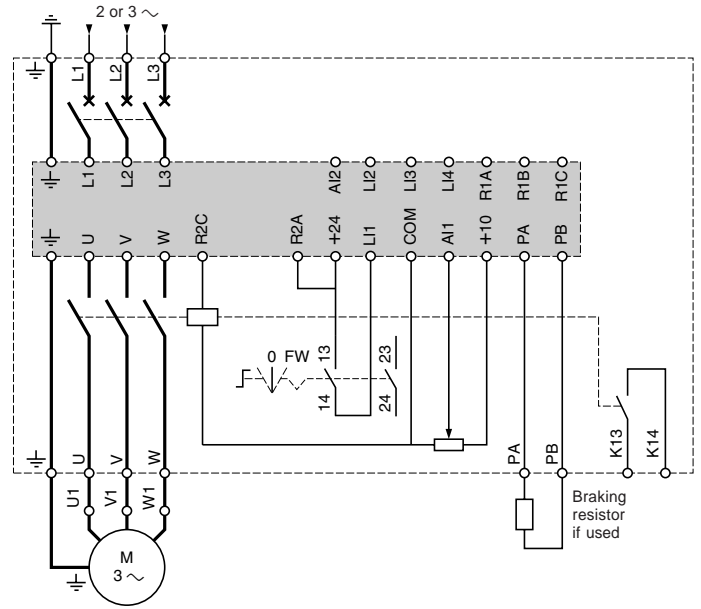

ATV-58ED12N4, ED16N4, ED23N4, ED28N4, ED33N4, ED46N4, ED54N4, ED64N4, ED79N4

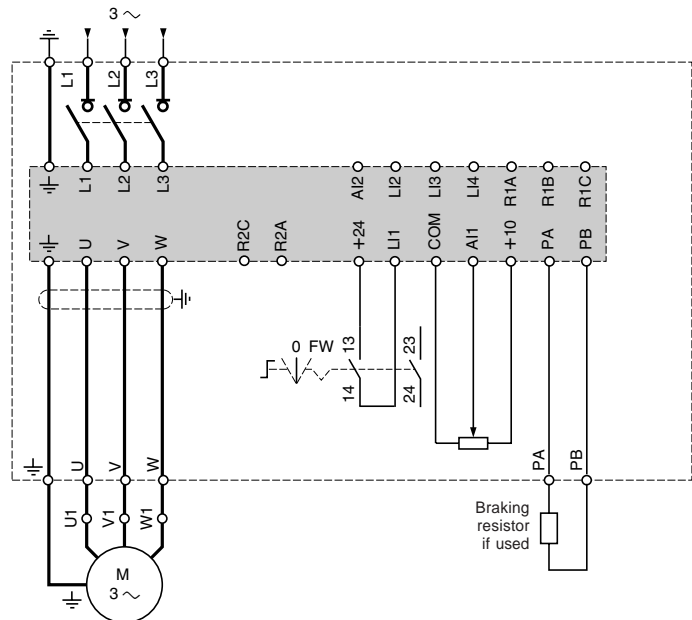

Variable speed controllers for asynchronous motors

Altivar 58

Combination of functions and applications

Functions :
pages 60133/2 to 60133/25

Applications	Special machines			Packing/packageging	
	Timber machines Textile machines	Mixers Kneaders Centrifuges	Dosing (pumps, screws, dosing belts)	Hoop casing machines Bagging machines Labelling machines	Palletisers Depalletisers
"Drive" functions					
Maximum frequency 500 Hz (special motor)					
Switching frequency	2 to 16 kHz	2 to 16 kHz	2 to 16 kHz	2 kHz	2 kHz
Noise reduction (random freq.)		■	■	■	■
Skip frequency		■			
Energy saving					
Automatic injection on stop	■	■		■	■
Resistance braking	■	□		■	■
Application functions					
Automatic adaption of the deceleration ramp	■	■		■	
Automatic catching a spinning load (flying restart)	■	■	■	■	
Automatic restart					
Controlled stop on loss of AC supply	■	■	□		
Lim. of the operating time at low speed					
S-shaped ramps					■
U-shaped ramps			□		
Adaptation of current limit					
Analogue inputs					
- Summing	□		□	■	
- Torque limit	□				
- PI regulator			□		
- PTC probe	□	□		□	□
- Tachogenerator speed feedback	□	□	■	□	□
Encoder input (speed regulation)	□	□	□		□
Logic inputs					
- 2 operating directions	■	■	□	■	■
- d.c. injection		■			
- Fast stop		□			
- Freewheel stop	■				
- Step by step (JOG)	□	□	□	□	□
- Preset speeds	■	■	□	■	■
- Ramp switching	□				
- +/- speed		□	■	□	
- Reference switching			□		
- Motor switching	□				■
- 2nd torque limit	□				
Logic outputs and relays					
- Brake sequence					■
- Downstream contactor control	□	□		□	
- Frequency threshold reached	□		■	□	□
- HSP reached		□			
- Reference reached	□	□	□	□	
- Current threshold reached		□	□		
- Thermal motor threshold reached					
- Controller running	□		■	□	□
Analogue output (torque, speed, current, ramp)	□	□	□	□	□

■ Frequent or essential use

□ Occasional use

Variable speed controllers for asynchronous

Presentation :
pages 60131/2 to 60131/6
Characteristics :
pages 60131/7 to 60131/9
References :
pages 60132/2 to 60132/4
Dimensions, schemes :
pages 60134/2 to 60135/8

Altivar 58

Functions

Summary of functions

Principle of access to menus	page 60133/3
Macro-configuration programming	page 60133/4
Operating power range - Operating speed range	page 60133/5
Acceleration and deceleration ramp times	page 60133/6
Acceleration and deceleration ramp profile	page 60133/6
Alternate ramp switching - Automatic adaptation of the deceleration ramp	page 60133/7
Reduction of torque limit by logic input	page 60133/8
Reduction of torque limit by analogue input	page 60133/8
Reverse operation - Disabling reverse - Step by step (JOG)	page 60133/9
2-wire control - 3-wire control	page 60133/10
+/- speed - Setpoint memory	page 60133/11
Brake sequence - Motor switching	page 60133/12
Downstream contactor control - Preset speeds - Setting analogue input AI2	page 60133/13
Summing inputs - Reference switching	page 60133/14
PI regulator - Speed feedback with tachogenerator	page 60133/15
Incremental speed feedback - Incremental speed reference	page 60133/16
Controlled stop - Controlled stop on mains power break	page 60133/17
Automatic catching a spinning load with speed search	page 60133/17
Automatic restart - Limitation of operating time at low speed	page 60133/18
Fault reset - Forced local mode - Fault relay, unlocking	page 60133/19
Thermal protection of the motor	page 60133/20
Thermal protection with PTC probes - Thermal protection of speed controller	page 60133/21
Switching frequency, noise reduction	page 60133/21
Energy saving - Adaptation of current limit	page 60133/22
Auto-tuning - Skip frequency	page 60133/22
Reassignable logic outputs - Analogue output AO - Adjustment of analogue output AO	page 60133/23
Configurable I/O	pages 60133/24, 60133/25

Variable speed controllers for asynchronous motors

Presentation :
pages 60131/2 to 60131/6
Characteristics :
pages 60131/7 to 60131/9
References :
pages 60132/2 to 60132/4
Dimensions, schemes :
pages 60134/2 to 60135/8

Altivar 58

Functions (continued)

Principle of access to menus

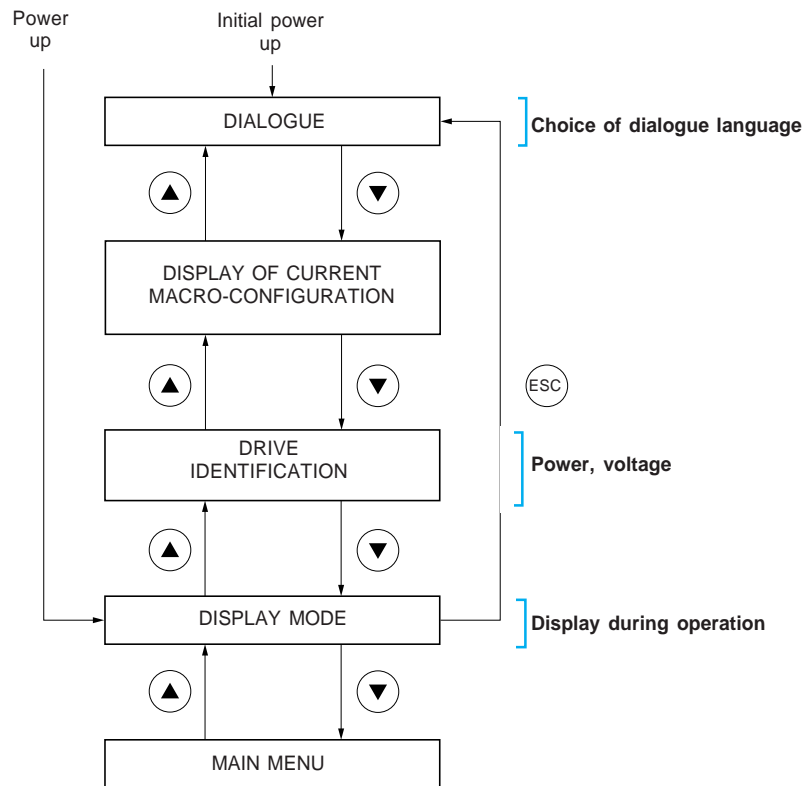

Principle of access in the main menu with the operator terminal

- With the terminal switch in position 0, the user can :
 - Select the dialogue language
 - Display the macro-configuration
 - Identify the speed controller
 - Display the state of the speed controller, the electrical values and the fault register
- With the terminal switch in position 1, the user can :
 - Perform the operations possible in position 0
 - Modify the settings
- With the terminal switch in position 2, the user can :
 - Perform the operations possible in positions 0 and 1
 - Change the macro-configuration
 - Modify the motor power
 - Modify all the configuration parameters
 - Enable control of the speed controller via the terminal
 - Store, load or protect the parameter files

Principle of access in the main menu with the programming terminal or with a PC

There are no access restrictions, except if an access code has already been entered.

Variable speed controllers for asynchronous motors

Presentation :
pages 60131/2 to 60131/6
Characteristics :
pages 60131/7 to 60131/9
References :
pages 60132/2 and 60132/4
Dimensions, schemes :
pages 60134/2 to 60135/8

Altivar 58

Functions (continued)

Macro-configuration programming

A simplified menu can be used for preprogramming the speed controller to facilitate configuration and installation.

There are 3 options available, which correspond to the various functions and applications :

- Handling
- General use
- Variable torque

The selection of one of these macro-configurations will automatically assign the functions, parameters and I/O, even for any option cards which may be used. This menu also includes a guide to the most appropriate selection in each case. Preconfiguration carried out in this way can be modified at any time if necessary.

In the "factory" configuration the selection is set to the "handling" macro-configuration.

The preconfigured functions for each macro-configuration are :

Type of macro-configuration	Handling	General use	Variable torque
Basic I/O			
Logic input LI1	Forward	Forward	Forward
Logic input LI2	Reverse	Reverse	Reverse
Logic input LI3	2 preset speeds	Jog operation	Reference switching
Logic input LI4	4 preset speeds	Freewheel stop	Injection braking
Analogue input AI1	Summing speed reference	Summing speed reference	Speed reference 1
Analogue input AI2	Summing speed reference	Summing speed reference	Speed reference 2
Relay R1	Speed controller fault	Speed controller fault	Speed controller fault
Relay R2	Downstream contactor control	Motor thermal state reached	Frequency reference reached
Extension card I/O			
Logic input LI5	8 preset speeds	Clearing faults	Freewheel stop
Logic input LI6	Clearing faults	Current limit	Ramp switching
Analogue input AI3 or Encoder inputs	Summing speed reference	Summing speed reference	PI regulator
	Speed regulation	Speed regulation	Speed regulation
Logic output LO	Current threshold reached	Downstream contactor control	High speed reached
Analogue output AO	Motor frequency	Motor frequency	Motor frequency

Variable speed controllers for asynchronous motors

Presentation :
pages 60131/2 to 60131/6
Characteristics :
pages 60131/7 to 60131/9
References :
pages 60132/2 to 60132/4
Dimensions, schemes :
pages 60134/2 to 60135/8

Altivar 58

Functions (continued)

Operating power range

Function

Operation of the speed controller at optimum power, according to whether the application requires standard overtorque (standard torque applications, 1.2 Tn) or high overtorque (high torque applications).

Applications

For speed controllers with a power rating greater than 7.5 kW at 208 to 240 V and 15 kW at 380 to 500 V, when this type of optimization offers significant cost reduction.

Operating speed range

Function

Determination of the 2 frequency limits defining the speed range permitted by the machine under actual operating conditions.

Applications

All applications with or without overspeed.

Settings

Normal mode

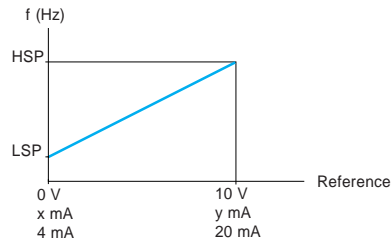

LSP : low speed, from 0 to HSP, preset at 0

HSP : high speed, from LSP to f_{max} , preset at 50/60 Hz

x : can be configured from 0 to 20 mA, preset at 4 mA.

y : can be configured from 4 to 20 mA, preset at 20 mA.

Pedestal mode

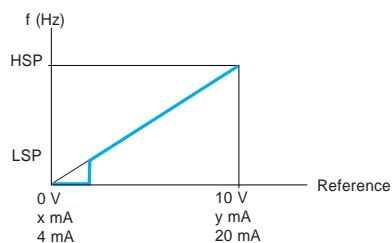

LSP : low speed, from 0 to HSP, preset at 0

HSP : high speed, from LSP to f_{max} , preset at 50/60 Hz

x : can be configured from 0 to 20 mA, preset at 4 mA

y : can be configured from 4 to 20 mA, preset at 20 mA.

Deadband mode

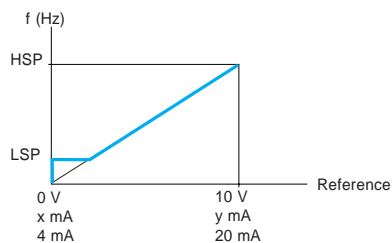

LSP : low speed, from 0 to HSP, preset at 0

HSP : high speed, from LSP to f_{max} , preset at 50/60 Hz

x : can be configured from 0 to 20 mA, preset at 4 mA

y : can be configured from 4 to 20 mA, preset at 20 mA.

Variable speed controllers for asynchronous motors

Presentation :
 pages 60131/2 to 60131/6
 Characteristics :
 pages 60131/7 to 60131/9
 References :
 pages 60132/2 to 60132/4
 Dimensions, schemes :
 pages 60134/2 to 60135/8

Altivar 58

Functions (continued)

Acceleration and deceleration ramp times

Function

Determination of the acceleration and deceleration ramp times according to the application and the dynamics of the machine.

Applications

All applications.

Settings

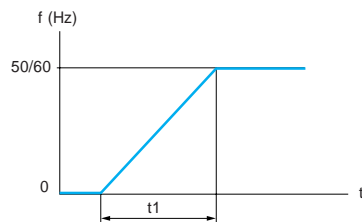

Acceleration

Adjustment from 0.05 to 999.9 s, preset at 3 s.

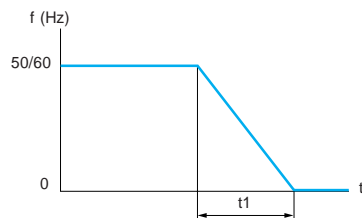

Deceleration

Adjustment from 0.05 to 999.9 s, preset at 3 s.

Acceleration and deceleration ramp profile

Function

Gradual change of output frequency from a speed reference, following a linear or a predetermined ratio which enables the ramps to be given an S or U-shape profile.

Applications

Materials handling, packaging, personnel transportation : the use of S ramps takes up mechanical play, eliminates jolts and limits "non-following" of speed during rapid transient operation of high inertia machines. Pumping (installations with centrifugal pumps and non-return valves) : the use of U ramps improves control over valve operation. Selecting "linear" or "S" or "U" ramps will affect both the deceleration and the acceleration ramp.

Settings

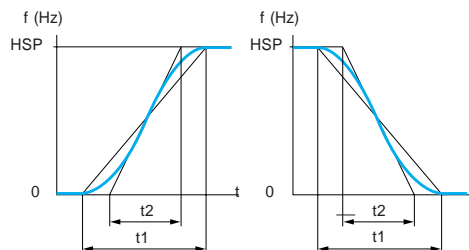

S ramps

The curve coefficient is fixed, with $\frac{t_2}{t_1} = 0.6$

Where t_1 = set ramp time

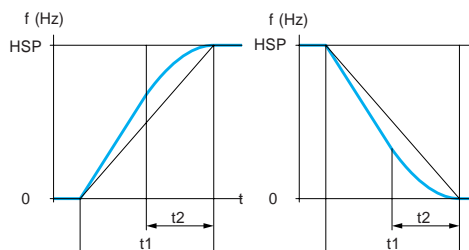

U ramps

The curve coefficient is fixed, with $t_2 = 0.5 \times t_1$.

Where t_1 = set ramp time

Variable speed controllers for asynchronous motors

Presentation :
pages 60131/2 to 60131/6
Characteristics :
pages 60131/7 to 60131/9
References :
pages 60132/2 to 60132/4
Dimensions, schemes :
pages 60134/2 to 60135/8

Altivar 58

Functions (continued)

Alternate ramp switching

Function

Switching of two acceleration and deceleration ramp times, which can be adjusted separately.
Validation : one logic input must be reassigned, or one frequency threshold must be defined.

Applications

Materials handling with smooth starting and approach
Machines with fast steady state speed correction
High speed lathes with limitation of acceleration and deceleration times above certain speeds

Settings

Acceleration and deceleration
Example of switching using input LI4

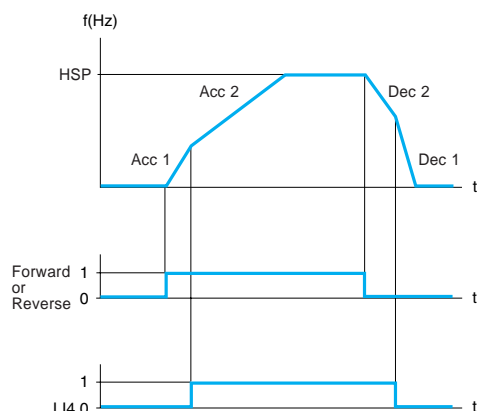

Acceleration 1 and deceleration 1 :
- adjustment 0.05 to 999.9 s
- preset at 3 s.

Acceleration 2 and deceleration 2 :
- adjustment 0.05 to 999.9 s,
- preset at 5 s.

Automatic adaptation of the deceleration ramp

Function

Automatic adaptation of the time of the deceleration ramp, if the initial setting is too low given the inertia of the load. This function avoids possible locking of the speed controller in the event of an **excessive braking** fault.

Applications

All applications not requiring precise stopping and not using braking resistors.

Setting

Yes or no. Factory set-up : depends on the macro-configuration.
Automatic adaptation must be cancelled if the machine has position control with stopping on a ramp and a braking resistor installed. This function will be automatically disabled if the braking sequence is configured.

Variable speed controllers for asynchronous motors

Presentation :
pages 60131/2 to 60131/6
Characteristics :
pages 60131/7 to 60131/9
References :
pages 60132/2 to 60132/4
Dimensions, schemes :
pages 60134/2 to 60135/8

Altivar 58

Functions (continued)

Reduction of torque limit by logic input

Function

Reduction of maximum motor torque, by assigning a logic input LI to this function.
Setting : 0 to 200 % of nominal motor torque in a high torque application.

Applications

Machines with risk of frequent jamming : conveyors, shredders, extruders.
Cutting to length with stop and maintaining motor torque over a mechanical travel limit.
Application using a motor with a lower power rating than the speed controller rating (motor switching).

Reduction of torque limit by analogue input

Function

Reduction of maximum motor torque, via the analogue input AI3 to be assigned to this function.
The I/O extension card with analogue input must be used.

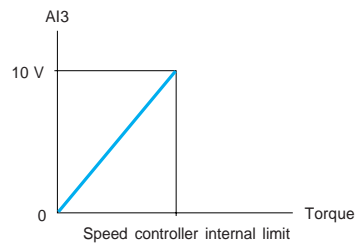

Applications

Correction of torque or traction.

Variable speed controllers for asynchronous motors

Presentation :
pages 60131/2 to 60131/6
Characteristics :
pages 60131/7 to 60131/9
References :
pages 60132/2 to 60132/4
Dimensions, schemes :
pages 60134/2 to 60135/8

Altivar 58

Functions (continued)

Reverse operation

Function

The direction of operation is reversed via logic input LI2 which is assigned to this function in the factory set-up. To disable this function in the case of an application with a single motor rotation direction, reassign input LI2 to another function.

Applications

All applications with 1 or 2 operating directions.

Disabling reverse

Function

- Disables operation in the opposite direction to that requested by the logic inputs, even if this is requested by a regulation or summation function.
- Disables reverse operation if requested using the REV button on the terminal.

Applications

When the operation should not be reversed (example : fan).

Step by step (JOG)

Function

Pulse operation with minimum ramp times (0.1 s), limited speed reference and minimum time between 2 pulses. Validation : adjustable logic input L1 assigned to this function and pulses provided by the operating direction command.

Applications

Machines with insertion of product in manual operation
Gradual advancing of the mechanism during a maintenance operation

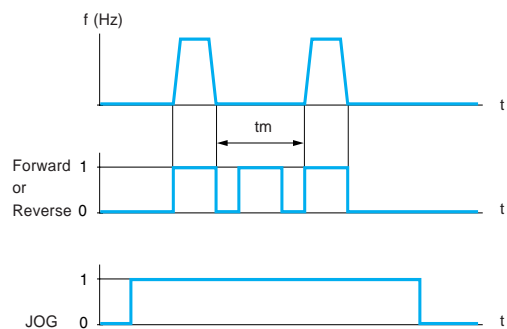

Speed reference :
- adjustment 0 to 10 Hz,
- preset at 10 Hz.

Minimum time t_m between 2 pulses:
- adjustment 0 to 2 s,
- preset at 0.5 s.

Variable speed controllers for asynchronous motors

Presentation :
pages 60131/2 to 60131/6
Characteristics :
pages 60131/7 to 60131/9
References :
pages 60132/2 to 60132/4
Dimensions, schemes :
pages 60134/2 to 60135/8

Altivar 58

Functions (continued)

2-wire control

Function

Control of direction of operation using stay-put contacts.
Validation : 1 or 2 logic inputs (1 or 2 directions of operation).

Applications

All operations with 1 or 2 operating directions.
3 possible operating modes :
- detection of state of logic inputs
- detection of a change in the state of logic inputs
- detection of the state of logic inputs with forward operation having priority over reverse

Example of wiring

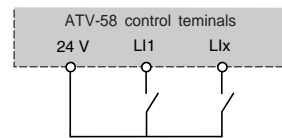

L11 : forward
L1x : reverse

3-wire control

Function

Control of the direction of operation and stopping using pulsed contacts.
Validation : 2 or 3 logic inputs (1 or 2 directions of operation).

Applications

All applications with 1 or 2 operating directions.

Example of wiring

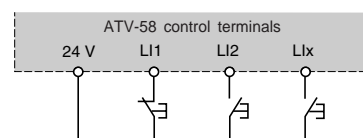

L11 : Stop
L12 : Forward
L1x : Reverse

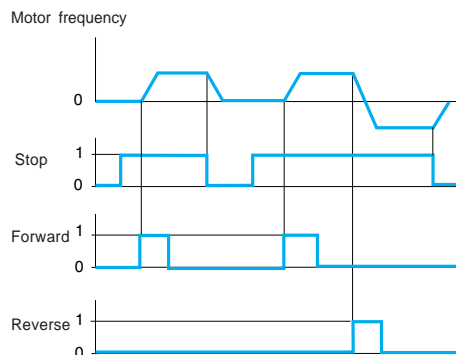

Variable speed controllers for asynchronous motors

Presentation :
 pages 60131/2 to 60131/6
 Characteristics :
 pages 60131/7 to 60131/9
 References :
 pages 60132/2 to 60132/4
 Dimensions, schemes :
 pages 60134/2 to 60135/8

Altivar 58

Functions (continued)

+/- speed

Function

Increase or decrease of speed reference using 1 or 2 logic signals with or without saving of the last reference (motorised potentiometer function). Maximum speed is given by the reference applied to the analogue inputs. Example : connect AI1 to + 10 V.

Validation : 1 or 2 logic inputs must be reassigned.

Applications

Centralised control of a machine which has several sections operating in one direction. Control, using a pendant control station, of a materials handling crane, in two operating directions.

- Example with saving of the last reference and 2 logic inputs

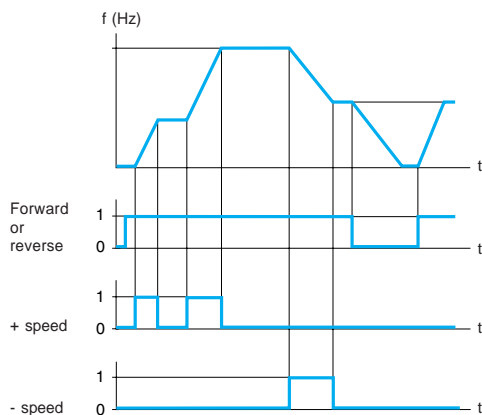

- Example without saving of the last reference and a single "+ speed" logic input (for example double action buttons)

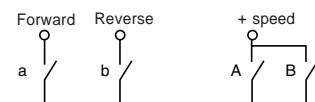

a and b : Press 1
 A and B : Press 2

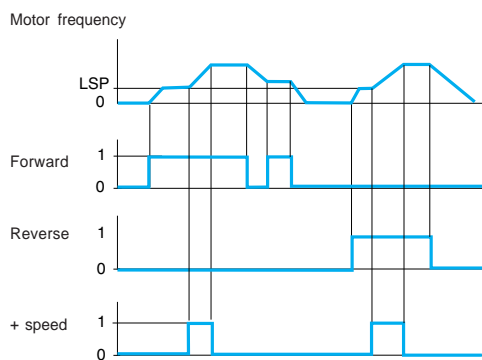

Note : this type of "+/- speed" control is incompatible with 3-wire control.

Setpoint memory

Function

Associated with the "+/- speed" command. Select yes or no.

Reading and storing of a speed reference level at the loss of the run signal or mains supply. The stored reference is applied to the next run signal.

Variable speed controllers for asynchronous motors

Presentation :
pages 60131/2 to 60131/6
Characteristics :
pages 60131/7 to 60131/9
References :
pages 60132/2 to 60132/4
Dimensions, schemes :
pages 60134/2 to 60135/8

Altivar 58

Functions (continued)

Brake sequence

Function

Managing the control of safety brakes in synchronisation with the starting and stopping of the motor in order to avoid jolts and load veering.

Brake control sequence managed by the speed controller

Adjustable brake release : frequency and current threshold, time delay

Adjustable brake engage : frequency, time delay

Validation : relay logic output R2 must be assigned to brake control

Applications

Materials handling with movements equipped with safety brakes (hoisting).

Machines requiring a parking brake (unbalanced machines).

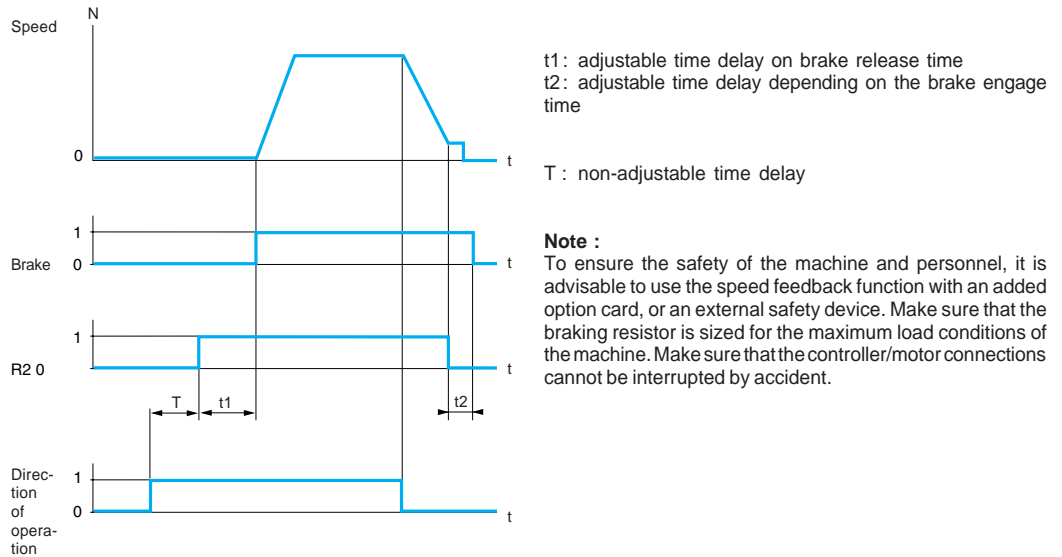

Motor switching

Function

Successive powering of two motors of different powers by the speed controller. Switching must be carried out at a standstill, controller locked, by an appropriate sequence on the speed controller output.

The function enables motor parameters to be adjusted. The following parameters are automatically switched :

- nominal motor current
- injection current
- brake release current threshold

The thermal protection of the motor is disabled by this function.

Validation : logic input LI assigned to this function.

Associated parameter : coefficient giving the relationship between the power of the smallest motor and the power of the speed controller : from 0.2 to 1.

Applications

In hoisting : a single speed controller can be used for both the vertical and horizontal movements.

Variable speed controllers for asynchronous motors

Presentation :
pages 60131/2 to 60131/6
Characteristics :
pages 60131/7 to 60131/9
References :
pages 60132/2 to 60132/4
Dimensions, schemes :
pages 60134/2 to 60135/8

Altivar 58

Functions (continued)

Downstream contactor control

Function

Enables the speed controller to control a contactor located between the speed controller and the motor. The request to close the contactor is made when the run signal appears. The request to open the contactor is made when there is no longer a run signal or current present in the motor (freewheel stop, speed controller locked or braking terminated).
Validation : logic output LO or relay R2.

Applications

- This function avoids frequent switching of the power circuit upstream of the speed controller (premature ageing of filter capacitors), and requires a specific connection diagram (see page 60135/4).
- **In the case of cycles < 60 s with isolation of the motor when stationary, it is essential to use this function.** Otherwise, the excessive frequency of operation of the line contactor may destroy the load resistor in the speed controller.
- Machines where the operation requires power to the motor to be removed when there is a stop to prevent any possibility of an untimely restart (example : materials handling carousel where items are put down and picked up manually).

This function can also be used to implement backup operation by direct supply of the motor via the mains supply (for machines requiring an emergency release function). The output can also be used both to control a downstream contactor and to authorise emergency operation ("bypass" function).

Preset speeds

Function

Switching preset speed references
Selecting between 2, 4 or 8 preset speeds
Validation : 1, 2 or 3 logic inputs

Applications

Materials handling and machines with several operating speeds.

Example with 4 speeds

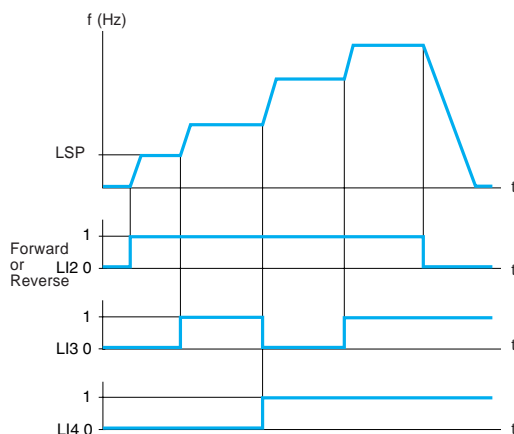

Speed obtained with inputs LI3 and LI4 at state 0 : LSP or speed reference depending on the level of analogue inputs AI1 and AI2.

Adjustment of preset speeds from 0.1 Hz up to maximum frequency.

Factory settings :

1st speed : LSP or reference

2nd speed : 5 Hz

3rd speed : 10 Hz

4th speed : HSP

Setting analogue input AI2

Function

It is possible to modify the characteristics of analogue current input AI2.
Factory setting : 0-20 mA.
Other values : 4-20 mA, 20-4 mA, or X-Y mA by programming X and Y with a resolution of 0.1 mA.

Applications

All applications with a current speed reference other than 4-20 mA.

Variable speed controllers for asynchronous motors

Presentation :
pages 60131/2 to 60131/6
Characteristics :
pages 60131/7 to 60131/9
References :
pages 60132/2 to 60132/4
Dimensions, schemes :
pages 60134/2 to 60135/8

Altivar 58

Functions (continued)

Summing inputs

Function

Analogue input AI2 (and/or the analogue input AI3 with extension card) can be assigned as a summing input for AI1 with peak limiting corresponding to the speed HSP.

Applications

Machines whose speed is controlled by a correction signal on input AI2.

References summed

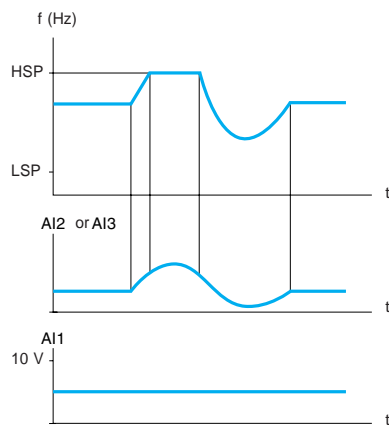

Reference switching

Function

Switching of 2 analogue references by logic command. This function avoids the switching of low-level signals, and enables the two reference inputs AI1 and AI2 to be independent.
Validation : 1 logic input LI must be reassigned.

Applications

All machines with automatic/manual operation
Automatic control via sensor on input AI2, validated by the logic input at state 0
Manual control via potentiometer on input AI1 (local control)

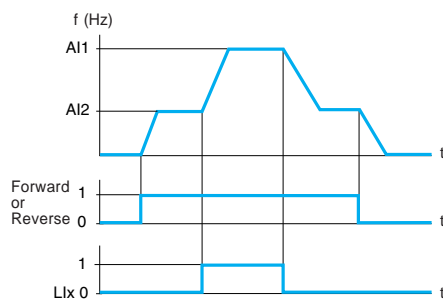

Connection diagram

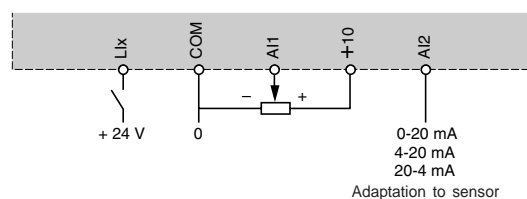

Variable speed controllers for asynchronous motors

Presentation :
pages 60131/2 to 60131/6
Characteristics :
pages 60131/7 to 60131/9
References :
pages 60132/2 to 60132/4
Dimensions, schemes :
pages 60134/2 to 60135/8

Altivar 58

Functions (continued)

PI regulator

AI1 is the reference. AI2 or AI3 can be assigned to feedback (AI3 with extension card/analogue input).

Function

Simple regulation of flow rate or pressure with a sensor sending a feedback signal adapted to the speed controller.

Applications

Pumping and ventilation.

Adjustable parameters

- proportional gain, 0.01 to 100
- integral gain, 0.01 to 100/second
- feedback multiplied by K from 1 to 100
- reverse or direct PI correction.

Connection diagram with feedback on AI2

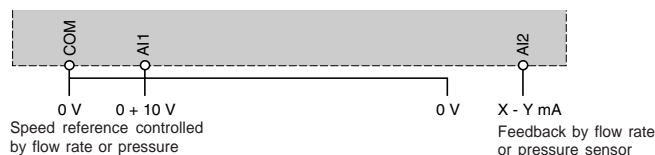

Connection diagram with feedback on AI3

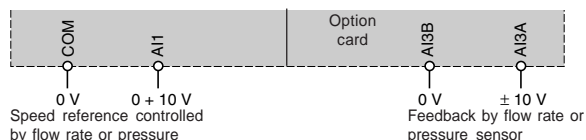

Notes :

The PI function is not compatible with the "preset speeds" and "step by step" (JOG) functions.
The PI reference can also be transmitted on line via the RS 485 serial link or via one of the communication cards.

Speed feedback with tachogenerator

Function

Accurate speed regulation, independent of motor load state.

Assignment on analogue input AI3, with extension card/analogue input

The voltage of the tachogenerator at maximum speed must be between 5 and 9 volts. If necessary, an external divider bridge may be used to set this value (1). An accurate setting for adjusting this value can be found in the "adjust" menu. The coherence between motor frequency and speed feedback is monitored in the speed controller's fault menu.

Applications

All applications requiring a very accurate speed independent of load.

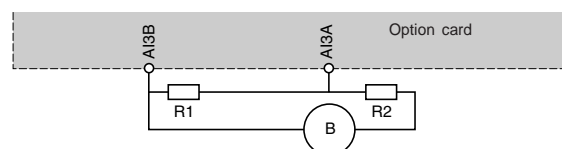

- (1) **Example** : motor 1500 rpm at 50 Hz, tachogenerator 0.06 V/rpm, maximum speed set at 75 Hz (speed 2250 rpm).
- maximum voltage $0.06 \times 2250 = 135$ V.
- recommended current for tachogenerator 10 mA, thus $R1 + R2 = 135/10 = 13.5$ k Ω
- average voltage on the input = 7 V, thus $R1 = 7/10 = 0.7$ k Ω or 680 Ω , nearest standard value
- $R2 = 13.5 - R1$, or 12 k Ω , nearest standard value
- exact voltage on AI3 = $135 \times R1/(R1 + R2) = 135 \times 0.68/12.68 = 7.24$ V. Use resistors with sufficient power (2 watts min).
Exact scaling of the speed feedback is to be performed by programming, at the time of installation.

Variable speed controllers for asynchronous motors

Presentation :
pages 60131/2 to 60131/6
Characteristics:
pages 60131/7 to 60131/9
References :
pages 60132/2 to 60132/4
Dimensions, schemes :
pages 60134/2 to 60135/8

Altivar 58

Functions (continued)

Incremental speed feedback

Function

Accurate speed regulation, independent of motor load state.

Assignment

On logic inputs A, A-, B, B- of the extension card/encoder inputs.
NPN open collector output, nominal voltage 24 V --- .
Max reading frequency 33 kHz at max speed HSP.

Use in 1 operating direction with an inductive sensor or photoelectric detector : simplified regulation, less accurate at low speed.

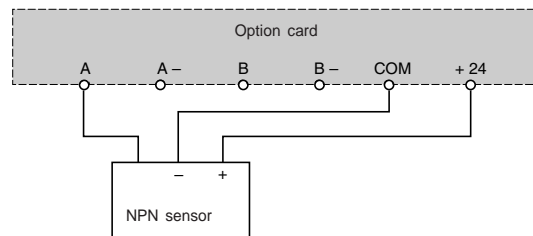

Use in 1 or 2 operating directions with incremental encoder for accurate regulation.

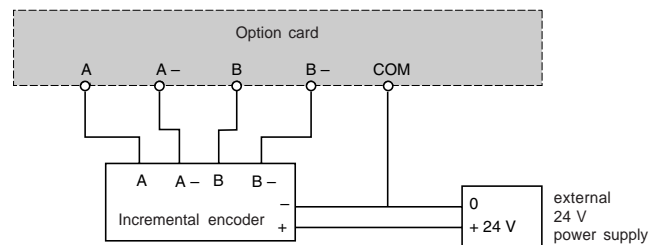

The coherence between motor frequency and speed feedback is monitored in the speed controller's fault menu.

Applications

All applications requiring accurate speed regulation independent of load, with good immunity to interference.

Incremental speed reference

Function

Assignment of logic inputs on the above extension card/encoder inputs to the "summing input" function.

Applications

Speed synchronisation of several speed controllers.
Nominal voltage 24 V --- .
Max reading frequency 33 kHz at max speed HSP.

Variable speed controllers for asynchronous motors

Presentation :
pages 60131/2 to 60131/6
Characteristics:
pages 60131/7 to 60131/9
References :
pages 60132/2 to 60132/4
Dimensions, schemes :
pages 60134/2 to 60135/8

Altivar 58

Functions (continued)

Controlled stop

Function

Determination of stopping methods in addition to the normal speed controller stop. These stop requests always have priority.

Choice of 3 stopping methods :

- "freewheel stop" : the speed controller locks and the motor stops according to the inertia and resistive torque
- fast stop : braking with deceleration ramp time divided by a coefficient adjustable from 1 to 10
- d.c. injection braking : adjustment of time (0 to 30 s, preset at 0.5 s) and current (10 % to 136 % of nominal speed controller current in a high torque application, preset at 70 %), possibility of obtaining continuous braking, which is automatically limited to another adjustable value (from 10 % to 100 % of nominal motor current, preset at 50 %) after 30 s.

Validation methods :

- 1 logic input LI which must be assigned : active at 0 for freewheel stop and fast stop, active at 1 for injection stop
- automatically on stop (frequency less than 0.1 Hz) for injection braking, this function can be combined with the others. In this case, only the current injected after 30 s can be adjusted.

Applications

- "freewheel" stop : applications with locking using electrical safety device
- fast stop : materials handling applications with emergency stop electrical braking
- d.c. injection braking : fans, this stopping mode does not generally require the addition of a braking resistor

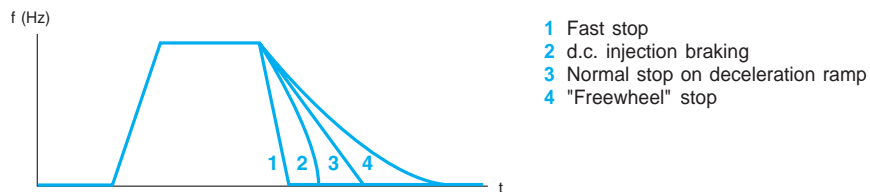

Controlled stop on mains power break

Function

Control of motor stopping on a mains power break, following a ramp which is self-adapting as a function of the restored kinetic energy.

Applications

Materials handling, machines with high inertia, continuous production processing machines.
Factory set-up : inactive

Automatic catching a spinning load with speed search ("flying restart")

Function

Restarting the motor without a speed surge following one of these events :

- mains power break or simple switch off
- fault reset or automatic restart
- freewheel stop or injection stop with logic input
- uncontrolled loss of power downstream of speed controller

On restart, the controller searches for the effective speed of the motor in order to restart on a ramp from this speed and return to the reference speed. The speed search time can reach 1 s depending on the initial difference.

Factory pre-set : active.

This function is automatically disabled if the brake sequence is configured.

Applications

Machines where motor speed does not drop rapidly during a mains power break (machines with high inertia), fans and pumps driven by residual flux etc.

Variable speed controllers for asynchronous motors

Presentation :
pages 60131/2 to 60131/6
Characteristics :
pages 60131/7 to 60131/9
References :
pages 60132/2 to 60132/4
Dimensions, schemes :
pages 60134/2 to 60135/8

Altivar 58

Functions (continued)

Automatic restart

Function

Automatic restart after locking of the speed controller on a fault, if the other operating functions are correct and the fault has disappeared.

This restart is made by a series of automatic attempts performed at 30 second intervals.

If the speed controller has not restarted after 6 attempts, it will lock and the procedure is abandoned until it is switched off and then on again.

Factory pre-set : inactive.

Faults which allow this restart are :

- excessive braking
- mains overvoltage
- motor thermal overload
- speed controller thermal overload
- 4-20 mA reference loss
- d.c. bus overvoltage
- external fault
- motor phase loss
- serial link fault
- mains voltage too low. For this fault, the function is always active, even if it has not been configured.

In the case of this fault, the controller fault relay remains energised if the function is configured. This function requires the speed reference and the operating direction to be maintained.

Applications

Machines or installations operating continuously or without supervision, which, when restarted, pose no danger to either equipment or personnel (pumps, fans, etc).

Limitation of the operating time at low speed (LSP)

Function

The motor is automatically stopped at the end of a period of operation at low speed (LSP) with zero reference and run signal present.

This time can be adjusted from 0.1 to 999.9 seconds or no limit. Preset at 5 s. Restart occurs automatically on a ramp when the reference reappears or on a break and re-establishment of the run signal.

Applications

Automatic Start/Stop of pressure regulated pumps

Variable speed controllers for asynchronous motors

Presentation :
pages 60131/2 to 60131/6
Characteristics:
pages 60131/7 to 60131/9
References :
pages 60132/2 to 60132/4
Dimensions, schemes :
pages 60134/2 to 60135/8

Altivar 58

Functions (continued)

Fault reset

Function

Resetting of faults by a logic input L1 which can be reassigned to this function. The starting conditions after reset are the same as those at a normal power-up

Two types of reset are available :

- **Type 1**
Fault reset :
 - overvoltage
 - overspeed
 - external fault
 - speed controller overheating
 - motor phase loss
 - d.c. bus overvoltage
 - loss of 4-20 mA
 - load veering
 - motor overload if thermal state is below 100
 - serial link fault

The mains undervoltage and mains phase loss faults will reset automatically when the supply returns to normal.

- **Type 2**
Inhibits all faults, including thermal protection functions (forced operation), except motor short-circuit.

Applications

- **Type 1**
Speed controllers which are difficult to access, for example on moving parts in materials handling systems.
- **Type 2**
Speed controllers where restart could be vital, for example :
 - furnace conveyor
 - smoke extraction station
 - machine with hardening products which need to be removed

Forced local mode

Function

Forcing local control mode (validation of control via the terminals and cancelling of control via serial link).

Validation

One logic input LI can be reassigned to this function.

Fault relay, unlocking

The fault relay is energised when the speed controller is powered up and there is no fault present. It contains a changeover contact.

- The speed controller is unlocked after a fault using one of the following methods :
- by powering down until the "ON" LED extinguishes then switching the power back on
 - by assigning a logic input to the "reset faults" function
 - by the "automatic restart" function, if it is configured

Variable speed controllers for asynchronous motors

Presentation :
pages 60131/2 to 60131/6
Characteristics:
pages 60131/7 to 60131/9
References :
pages 60132/2 to 60132/4
Dimensions, schemes :
pages 60134/2 to 60135/8

Altivar 58

Functions (continued)

Thermal protection of the motor

Function

Indirect thermal protection of the motor by continuous calculation of its theoretical temperature rise.

Locking of the speed controller on a fault if this temperature rise exceeds 118 % of the nominal temperature rise.

Applications

- All applications with self-cooled or force-cooled motor

The microprocessor calculates the theoretical temperature rise of the motor using various elements :

- operating frequency
- current taken by the motor
- operating time
- maximum ambient temperature of 40 °C around the motor

Adjustments :

- 0.25 to 1.36 times the nominal current of the speed controller for high torque applications, preset at 0.9 times
- adjust to the nominal current indicated on the motor rating plate

Note : When the speed controller de-energises, the I^2t calculation is saved and its fall is calculated.

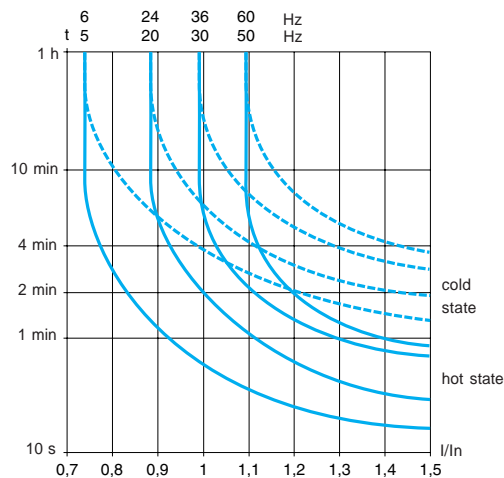

- Special uses

Adaptation of thermal protection in the fault configuration menu :

- applications with force-cooled motors : in this case, the tripping curves are those shown above for the nominal frequency 50/60 Hz
- inhibition of thermal protection in harsh environments : temperature above 40 °C around the motor, risk of cooling fins becoming clogged (provide direct thermal protection using PTC thermistor probes built into the motor)
- protection of motor using PTC probes : see the thermal protection with PTC probes function with option card
- in the case of motors connected in parallel on the same speed controller, each motor starter must be fitted with a thermal overload relay, in order to compensate for any risk of unequal distribution of loads

Variable speed controllers for asynchronous motors

Presentation :
pages 60131/2 to 60131/6
Characteristics:
pages 60131/7 to 60131/9
References :
pages 60132/2 to 60132/4
Dimensions, schemes :
pages 60134/2 to 60135/8

Altivar 58

Functions (continued)

Thermal protection with PTC probes

Function

Thermal protection of the motor, if it is equipped with PTC probes.

To be assigned to analogue input AI3, with extension card/analogue input.
Maximum resistance of probe circuit at 20 °C : 750 Ω (3 x 250 Ω probes in series).
The probe break and probe short-circuit faults are monitored.

Applications

All applications.

Thermal protection of speed controller

Function

Direct protection via a thermistor fixed to the heatsink, ensuring the protection of components even in the case of faulty ventilation or excessive ambient temperature.

Locking of speed controller on fault.

Switching frequency, noise reduction

Function

High frequency switching of the intermediate d.c. voltage can be used to supply the motor with a current wave with low harmonic distortion.

The switching frequency can be adjusted to reduce the noise generated by the motor :

- **Without derating, for continuous or intermittent duty (0.5 and 1 kHz frequencies are used for especially long cables)**

Speed controllers	Configurable switching frequencies kHz
ATV-58●U09M2 to ●D12M2 ATV-58HD16M2X and HD23M2X ATV-58●U18N4 to ●D46N4 ATV-58HD28N4X to HD46N4X	0,5-1-2-4
ATV-58HD28M2X to HD46M2X ATV-58●D54N4 to ●D79N4 ATV-58HD54N4X to HD79N4X	0,5-1-2

- **Without derating, with intermittent operating cycle or with derating by one rating in continuous duty (1)**

Speed controllers	Configurable switching frequencies kHz
ATV-58●U09M2 to ●D12M2 ATV-58●U18N4 to ●D23N4	8-12-16
ATV-58HD16M2X and HD23M2X ATV-58●D28N4 to ●D46N4 ATV-58HD28N4X to HD46N4X	8-12
ATV-58HD28M2X to HD46M2X ATV-58●D54N4 to ●D79N4 ATV-58HD54N4X to HD79N4X	4-8

Additionally, the switching frequency is random to avoid resonance phenomena. This function can be inhibited if it causes instability.

Applications

All applications which require a low level of motor noise.

(1) In intermittent duty, automatic frequency reduction in the case of overheating.

Variable speed controllers for asynchronous motors

Presentation :
pages 60131/2 to 60131/6
Characteristics:
pages 60131/7 to 60131/9
References :
pages 60132/2 to 60132/4
Dimensions, schemes :
pages 60134/2 to 60135/8

Altivar 58

Functions (continued)

Energy saving

Function

Adaptation of power taken according to the load, improved efficiency.

Applications

Variable torque and reduced torque applications.

Adaptation of current limit

Function

Automatic adaptation of current limit according to the speed to avoid a motor overload fault.

Application

Fans where the load curve changes according to air density.

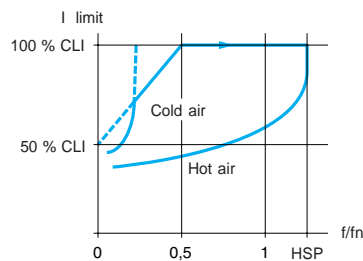

Auto-tuning

Function

The auto-tuning function can only be performed by voluntary action via the dialogue tools and by an assignable logic input. It is used to optimise performance.

Applications

All applications.

Skip frequency

Function

Suppression of a critical speed which causes mechanical resonance phenomena. It is possible to prohibit the prolonged operation of the motor within a frequency band of 5 Hz, adjustable over the speed range.

Applications

- Lightweight machines, bulk product conveyors with unbalanced motor
- Fans, centrifugal pumps

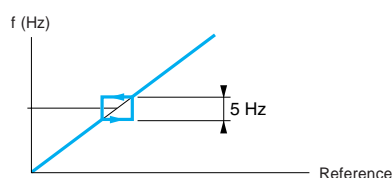

Factory pre-set : f1 = 0

Variable speed controllers for asynchronous motors

Presentation :
pages 60131/2 to 60131/6
Characteristics:
pages 60131/7 to 60131/9
References :
pages 60132/2 to 60132/4
Dimensions, schemes :
pages 60134/2 to 60135/8

Altivar 58

Functions (continued)

Reassignable logic outputs

Function

Relay R2 or output LO closed for :

- **Remote indication of the following information, according to preference :**
 - speed controller operating (running or braking)
 - frequency threshold reached (higher than or equal to an adjustable threshold)
 - frequency reference reached (motor frequency equal to the reference)
 - current threshold reached (higher than or equal to an adjustable threshold)
 - thermal threshold reached (higher than or equal to an adjustable threshold)
 - high speed reached
 - **Remote control**
 - brake sequence (relay R2 only)
 - downstream contactor control
-

Analogue output AO

Function

Assignment of the x-y mA analogue output on one of the I/O extension option cards to the following parameters, according to preference :

- motor current (y mA = 2 times the nominal current of the speed controller)
- motor frequency (y mA = maximum frequency),
- ramp output (y mA = maximum frequency),
- motor torque (y mA = 2 times the nominal motor torque).
- signed motor torque (x mA = - 2 times the nominal motor torque, that is braking operation, y mA = + 2 times the nominal motor torque).

Notes :

x adjustable from 0 to 20.
y adjustable from 0 to 20.

Adjustment of analogue output AO

Function

Possibility of modifying the characteristics of the analogue current output AO.

Preset to : 0-20 mA.

Other values: 4-20 mA, 20-4 mA or x-y mA by programming x and y with a definition of 0.1 mA.

Applications

All applications with signal other than 0-20 mA.

Variable speed controllers for asynchronous motors

Presentation :
pages 60131/2 to 60131/6
Characteristics:
pages 60131/7 to 60131/9
References :
pages 60132/2 to 60132/4
Dimensions, schemes :
pages 60134/2 to 60135/8

Altivar 58

Functions (continued)

Configurable I/O - Table of configurable I/O function compatibility

Only functions which may be incompatible with other functions are listed in this table.

- Stop functions have priority over run commands.
- Speed references via logic command have priority over analogue setpoints.

The choice of functions is limited :

- by the number of speed controller inputs and outputs to be reassigned : if necessary add an I/O extension card
- by the incompatibility of certain functions with others.

Functions	d.c. injection braking	Summing inputs	PI regulator	+ / - speed	Reference switching	Freewheel stop	Fast stop	JOG operation	Preset speeds	Speed regulation with tachogenerator or encoder	Torque limitation by AI3	Torque limitation by LI
d.c. injection braking						↑	↑					
Summing inputs					⊖							
PI regulator								⊖	⊖	⊖		
+ / - speed					⊖			↑	⊖			
Reference switching		⊖		⊖					⊖			
Freewheel stop	←						←					
Fast stop	←					↑						
JOG operation			⊖	←					←			
Preset speeds			⊖	⊖	⊖			↑				
Speed regulation with tachogenerator or encoder			⊖									
Torque limitation by AI3												⊖
Torque limitation by LI											⊖	

⊖ Incompatible functions

Compatible functions

Not applicable

Priority functions (functions which cannot be active simultaneously) :

← The arrow indicates which function has priority.

Example : the "Fast stop" function has priority over the "d.c. injection braking" function.

Variable speed controllers for asynchronous motors

Presentation :
pages 60131/2 to 60131/6
Characteristics:
pages 60131/7 to 60131/9
References :
pages 60132/2 to 60132/4
Dimensions, schemes :
pages 60134/2 to 60135/8

Altivar 58

Functions (continued)

Configurable I/O (continued) - Summary table of configurable I/O assignments

Speed controller I/O	With optional I/O extension cards		2 logic inputs LI5-LI6	Analogue input AI3	Logic output LO	Analogue output(s) AO	Encoder inputs A-, A+, B-, B+	
	Without option	Relay R2	Analogue input AI2	3 logic inputs LI2-LI3-LI4				
Possible assignment	Auto tuning							
	Reverse operation							
	Alternate ramp switching							
	Step by step (JOG)							
	+ / - speed							
	Preset speeds							
	Reference switching							
	Freewheel stop							
	d.c. injection stop							
	Fast stop							
	Motor switching							
	Second torque limit							
	Forced local mode							
	Fault reset							
	Summing reference							
	PI regulator							
	2nd speed reference							
	Speed feedback							
	PTC probes							
	Torque limit reduction							
	Downstream control							
	Frequency threshold reached							
	High speed reached							
	Frequency reference reached							
	Current threshold reached							
	Thermal threshold reached							
	Speed controller running							
	Brake sequence							
	Motor current							
	Motor frequency							
	Ramp output							
	Motor torque							